

**INVITATION TO BID**  
**CITY OF NAPLES**  
**PURCHASING DIVISION**  
**CITY HALL, 735 8<sup>TH</sup> STREET SOUTH**  
**NAPLES, FL 34102**  
**PH: 239-213-7100    FX: 239-213-7105**

**Cover Sheet**

NOTIFICATION DATE: <b>12/05/17</b>	TITLE <b>Decorative Street Signs</b>	SOLICITATION NUMBER: <b>18-015</b>	OPENING DATE & TIME: <b>01/11/18 2:00 PM</b>
<b>PRE-BID CONFERENCE DATE, TIME AND LOCATION:</b> A non-mandatory Pre-Proposal conference will be held December 12, 2017 at 10:00 A.M. local time in the Purchasing Division located at 735 8th St – S, Naples FL, 34102			

LEGAL NAME OF PARTNERSHIP, CORPORATION OR INDIVIDUAL:		
MAILING ADDRESS:		
CITY-STATE-ZIP:		
PH:	EMAIL:	
FX:	WEB ADDRESS:	
AUTHORIZED SIGNATURE	DATE	PRINTED NAME/TITLE
<p>I certify that this bid is made without prior understanding, agreement, or connection with any corporation, firm, or person submitting a bid for the same materials, supplies, or equipment and is in all respects fair and without collusion or fraud. I agree to abide by all conditions of this bid and certify that I am authorized to sign this bid for the bidder. In submitting a bid to the City of Naples the bidder offers and agrees that if the bid is accepted, the bidder will convey, sell, assign or transfer to the City of Naples all rights, title, and interest in and to all causes of action it may now or hereafter acquire under the Anti-trust laws of the United States and the State of FL for price fixing relating to the particular commodities or services purchased or acquired by the City of Naples. At the City's discretion, such assignment shall be made and become effective at the time the City tenders final payment to the bidder.</p> <p style="text-align: center;"><b>FEI/EIN Number _____</b></p> <p style="text-align: center; font-size: small;">Please initial by all that apply          I acknowledge receipt/ review of the following addendum          _____Addendum #1      _____Addendum #2      _____Addendum #3      _____Addendum #4</p>		

**PLEASE NOTE THE FOLLOWING**

- > **This page must be completed and returned with your bid.**
- > **Bids must be submitted in a sealed envelope, marked with solicitation number & opening date.**
- > **All submissions must be received and date stamped by Purchasing staff prior to the above "OPENING DATE & TIME".**
- > **Submission received after the above opening date and time will not be accepted.**
- > **Evaluation scores will be available on the City of Naples web site [www.naplesgov.com](http://www.naplesgov.com) . If you do not have computer access and want a copy of the evaluation scores, please enclose a stamped, self-addressed envelope with your bid.**

## GENERAL CONDITIONS

**TO ENSURE ACCEPTANCE OF THE PROPOSAL, PLEASE FOLLOW THESE INSTRUCTIONS. ANY AND ALL SPECIAL CONDITIONS, ATTACHED HERETO, HAVE PRECEDENCE.**

- 1. SEALED PROPOSAL:** All proposals must be submitted in a sealed envelope. The face of the envelope shall contain the proposal name and proposal number. Proposals not submitted on attached cover form shall be rejected. All proposals are subject to the conditions specified herein. Those which do not comply with these conditions are subject to rejection.
- 2. EXECUTION OF PROPOSAL:** Proposal must contain a manual signature of authorized representative in the proposal section. Proposal must be typed or printed in ink. Use of erasable ink is not permitted. All corrections made by proposer to his proposal must be initialed.
- 3. NO PROPOSAL:** If not submitting a proposal, respond by returning the Statement of No Proposal and explain the reason in the spaces provided. Failure to respond 3 times in succession without justification shall be cause for removal of the supplier's name from the proposal mailing list. NOTE: To qualify as a respondent, proposer must submit a "NO PROPOSAL," and it must be received no later than the stated proposal opening date and hour.
- 4. PROPOSAL OPENING:** Shall be public, on the date and at the time specified on the proposal form. It is the proposer's responsibility to assure that his proposal is delivered at the proper time and place of the proposal opening. Proposals which for any reason are not so delivered will not be considered. Offers by telegram; telephone; or fax are not acceptable. Proposal files may be examined during normal working hours.
- 5. WITHDRAWAL OF PROPOSALS:** Withdrawal of a proposal within sixty (60) days after the opening of proposals is subject to suspension or debarment in accordance with Policy 7-4 for up to three years.
- 6. PRICES, TERMS and PAYMENT:** Firm Prices shall be proposal and include all packing, handling, shipping charges and delivery to the destination shown herein. Proposer is encouraged to offer cash discount for prompt invoice payment. Terms of less than 20 days will not be considered.

  - A. TAXES:** The City of Naples does not pay Federal Excise and Sales taxes on direct purchases of tangible personal property. See exemption number on face of purchase order. This exemption does not apply to purchases of tangible personal property made by contractors who use the tangible personal property in the performance of contracts for the improvement of City-owned real property.
  - B. MISTAKES:** Proposers are expected to examine the specifications, delivery schedule, proposal prices, extensions, and all instructions pertaining to supplies and services. Failure to do so will be at proposer's risk. In case of mistake in extension, the unit price will govern.
  - C. CONDITION AND PACKAGING:** It is understood and agreed that any item offered or shipped as a result of this proposal shall be a new, current standard production model available at the time of this proposal. All containers shall be suitable for storage or shipment, and all prices shall include standard commercial packaging.
  - D. SAFETY STANDARDS:** Unless otherwise stipulated in the proposal, all manufactured items and fabricated assemblies shall comply with applicable requirements of Occupational Safety and Health Act and any standards there under.
  - E. UNDERWRITERS' LABORATORIES:** Unless otherwise stipulated in the proposal, all manufactured items and fabricated assemblies shall carry U.L. approval and re-examination listing where such has been established.
  - F. PAYMENT:** Payment will be made by the buyer after the items awarded to a vendor have been received, inspected, and found to comply with award specifications, free of damage or defect and properly invoiced. All invoices shall bear the purchase order number. Payment for partial shipments shall not be made unless specified in the proposal. Failure to follow these instructions may result in delay in processing invoices for payment. In addition, the purchase order number must appear on bills of lading, packages, cases, delivery lists and correspondence.
- 7. DELIVERY:** Unless actual date of delivery is specified (or if specified delivery cannot be met), show number of days required to make delivery after receipt of purchase order in space provided. Delivery time may become a basis for making an award (see Special Conditions). Delivery shall be within the normal working hours of the user, Monday through Friday, unless otherwise specified.
- 8. MANUFACTURERS' NAMES AND APPROVED EQUIVALENTS:** Any manufacturers' names, trade names, brand names, information and/or catalog numbers listed in a specification are for information and not intended to limit competition. The proposer may offer any brand for which he is an authorized representative, which meets or

exceeds the specification for any item(s). If proposals are based on equivalent products, indicate on the proposal form the manufacturer's name and number. Proposer shall submit with his proposal, cuts, sketches, and descriptive literature, and/or complete specifications. Reference to literature submitted with a previous proposal will not satisfy this provision. The proposer shall also explain in detail the reason(s) why the proposed equivalent will meet the specifications and not be considered an exception thereto. Proposals which do not comply with these requirements are subject to rejection. Proposals lacking any written indication of intent to quote an alternate brand will be received and considered in complete compliance with the specifications as listed on the proposal form.

**9. INTERPRETATIONS:** Any questions concerning conditions and specifications shall be directed in writing to this office for receipt no later than ten (10) days prior to the proposal opening. Inquiries must reference the date of proposal opening and proposal number. Failure to comply with this condition will result in proposer waiving his right to dispute the proposal.

**10. CONFLICT OF INTEREST:** All proposal awards are subject to Section 2-973 Conflict of Interest, City of Naples Code of Ordinances, which states: *"No public officer or employee shall have or hold any employment or contractual relationship with any business entity or any agency which is subject to the regulation of or is doing business with the city; nor shall an officer or employee have or hold any employment or contractual relationship that will create a continuing or frequently recurring conflict between his private interests and the performance of his public duties or that would impede the full and faithful discharge of his public duties. Any member of the city council or any city officer or employee who willfully violates this section shall be guilty of malfeasance in office or position and shall forfeit his office or position. Violation of this section with the knowledge, express or implied, of the person or corporation contracting with or making a sale to the city shall render the contract or sale voidable by the city manager or the city council."*

**11. AWARDS:** As the best interest of the City may require, the right is reserved to make award(s) by individual item, group of items, all or none, or a combination thereof; to reject any and all proposals or waive any minor irregularity or technicality in proposals received.

**12. ADDITIONAL QUANTITIES:** For a period not exceeding ninety (90) days from the date of acceptance of this offer by the buyer, the right is reserved to acquire additional quantities up to but not exceeding those shown on proposal at the prices proposal in this invitation. If additional quantities are not acceptable, the proposal sheets must be noted "PROPOSAL IS FOR SPECIFIED QUANTITY ONLY." (THIS PARAGRAPH DOES NOT APPLY FOR A TERM CONTRACT.)

**13. SERVICE AND WARRANTY:** Unless otherwise specified, the proposer shall define any warranty service and replacements that will be provided during and subsequent to this contract. Proposers must explain on an attached sheet to what extent warranty and service facilities are provided.

**14. SAMPLES:** Samples of items, when called for, must be furnished free of expense, on or before proposal opening time and date, and if not destroyed may, upon request, be returned at the proposer's expense. Each individual sample must be labeled with proposer's name, manufacturer's brand name and number, proposal number and item reference. Request for return of samples shall be accompanied by instructions which include shipping authorization and name of carrier and must be received with your proposal. If instructions are not received within this time, the commodities shall be disposed of by the City of Naples.

**15. PROPOSAL PROTEST:** The city has formal proposal protest procedures that are available on request.

**16. INSPECTION, ACCEPTANCE AND TITLE:** Inspection and acceptance will be at destination unless otherwise provided. Title and risk of loss or damage to all items shall be the responsibility of the contract supplier until accepted by the ordering agency, unless loss or damage results from negligence by the ordering

**17. DISPUTES:** In case of any doubt or difference of opinion as to the items to be furnished hereunder, the decision of the buyer shall be final and binding on both parties.

**18. GOVERNMENTAL RESTRICTIONS:** In the event any governmental restrictions may be imposed which would necessitate alteration of the material, quality, workmanship or performance of the items offered on this proposal prior to their delivery, it shall be the responsibility of the successful proposer to notify the buyer at once, indicating in his letter the specific regulation which required an alteration. The City reserves the right to accept any such alteration, including any price adjustments occasioned thereby, or to cancel the contract at no expense to the City.

**19. LEGAL REQUIREMENTS:** Applicable provision of all Federal, State, county and local laws, and of all ordinances, rules, and regulations shall govern development submittal and evaluation of all proposals received in response hereto and shall govern any and all claims and disputes which may arise between person(s) submitting a proposal response hereto and the City of Naples by and through its officers, employees and authorized representatives, or any other person, natural or otherwise; and lack of knowledge by any proposer shall not constitute a cognizable defense against the legal effect thereof.

**20. PATENTS AND ROYALTIES:** The proposer, without exception, shall indemnify and save harmless the City of Naples and its employees from liability of any nature or kind, including cost and expenses for or on account of any copyrighted, patented, or unpatented invention, process, or article manufactured or used in the performance of the contract, including its use by the City of Naples. If the proposer uses any design, device, or materials covered by letters, patent or copyright, it is mutually agreed and understood without exception that the proposal prices shall include all royalties or cost arising from the use of such design, device, or materials in any way involved in the work.

**21. ADVERTISING:** In submitting a proposal, proposer agrees not to use the results there from as a part of any commercial advertising.

**22. ASSIGNMENT:** Any Purchase Order issued pursuant to this proposal invitation and the monies which may become due hereunder are not assignable except with the prior written approval of the buyer.

**23. LIABILITY:** The supplier shall hold and save the City of Naples, its officers, agents, and employees harmless from liability of any kind in the performance of this contract.

**24. PUBLIC ENTITY CRIMES:** A person or affiliate who has been placed on the convicted vendor list following a conviction for a public entity crime may not submit a proposal on a contract to provide any goods or services to a public entity, may not submit a proposal on a contract with a public entity for the construction or repair of a public building or public work, may not submit proposals on leases of real property to a public entity, may not be awarded or perform work as a contractor, supplier, subcontractor, or consultant under a contract with any public entity, and may not transact business with any public entity in excess of the threshold amount provided in Section 287.017, for CATEGORY TWO for a period of 36 months from the date of being placed on the convicted vendor list.

**25. DISCRIMINATION:** An entity or affiliate who has been placed on the discriminatory vendor list may not submit a proposal on a contract to provide goods or services to a public entity, may not submit a proposal on a contract with a public entity for the construction or repair of a public building or public work, may not submit proposals on leases of real property to a public entity, may not award or perform work as a contractor, supplier, subcontractor, or consultant under contract with any public entity, and may not transact business with any public entity.

**26. COUNTY TAXES:** No proposal shall be accepted from and no contract will be awarded to any person, firm or corporation that is in arrears to the government of Collier County, Florida.

**27. OFFER EXTENDED TO OTHER GOVERNMENTAL ENTITIES:** The City of Naples encourages and agrees to the successful proposer extending the pricing, terms and conditions of this solicitation or resultant contract to other governmental entities at the discretion of the successful proposer.

**IF THIS PROPOSAL IS FOR A TERM CONTRACT, THE FOLLOWING CONDITIONS SHALL ALSO APPLY**

**28. ELIGIBLE USERS:** All departments of the City of Naples are eligible to use this term contract. Such purchases shall be exempt from the competitive proposal requirements otherwise applying to their purchases.

**29. PRICE ADJUSTMENTS:** Any price decrease effectuated during the contract period by reason of market change shall be passed on to City of Naples. Price increases are not acceptable.

**30. CANCELLATION:** All contract obligations shall prevail for at least one hundred eighty (180) days after effective date of contract. After that period, for the protection of both parties, this contract may be cancelled in whole or in part by either party by giving thirty (30) days prior written notice to the other party.



**31. RENEWAL:** The City of Naples reserves the option to renew the period of this contract, or any portion thereof for up to two (2) additional periods. Renewal of the contract period shall be by mutual agreement in writing.

**32. ABNORMAL QUANTITIES:** While it is not anticipated, should any unusual or abnormal requirements arise, the City reserves the right to solicit separate proposals thereon.

**33. FISCAL NON-FUNDING CLAUSE:** In the event sufficient funds are not budgeted for a new fiscal period, the City shall notify the contractor of such occurrence and the contract shall terminate on the last day of the current fiscal year without penalty or expense to the City.

**IF THIS PROPOSAL IS FOR PERFORMING A SERVICE, THE FOLLOWING CONDITIONS SHALL ALSO APPLY**

**34. ALTERNATIVE PROPOSALS:** Proposers offering service delivery methods other than those permitted by the scope of work may submit a separate envelope clearly marked "ALTERNATIVE PROPOSAL". Alternative proposals will be deemed non-responsive and will not be considered for award. All such responses will, however, be examined prior to award. Such examination may result in cancellation of all proposals received to permit rewriting the scope of work to include the alternative method, or the alternative method may be considered for future requirements of the City of Naples.

**35. ANTITRUST:** By entering into a contract, the contractor conveys, sells, assigns and transfers to the City of Naples all rights, titles and interest it may now have or hereafter acquire under the antitrust laws of the United States and the State of Florida that relate to the particular goods or services purchased or acquired by the City of Naples under said contract.

**36. PROPOSER INVESTIGATIONS:** Before submitting a proposal, each proposer shall make all investigations and examinations necessary to ascertain all site conditions and requirements affecting the full performance of the contract and to verify any representations made by the City of Naples upon which the proposer will rely. If the proposer receives an award as a result of its proposal submission, failure to have made such investigations and examinations will in no way relieve the proposer from its obligation to comply in every detail with all provisions and requirements of the contract documents, nor will a plea of ignorance of such conditions and requirements be accepted as a basis for any claim whatsoever by the contractor for additional compensation.

**37. CERTIFICATES AND LICENSES:** The Contractor, at time of proposal, shall possess the correct occupational licenses, all professional licenses or other authorizations necessary to carry out and perform the work required by the City of Naples and Collier County for this project pursuant to all applicable Federal, State and Local Laws, Statutes, Ordinances, and rules and regulations of any kind.

**38. CHANGE IN SCOPE OF WORK:** The City of Naples may order changes in the work consisting of additions, deletions or other revisions within the general scope of the contract. No claims may be made by the contractor that the scope of the project or of the contractor's services has been changed, requiring changes to the amount of compensation to the contractor or other adjustments to the contract unless such changes or adjustments have been made by written amendment to the contract signed by the City of Naples and the contractor. If the contractor believes that any particular work is not within the scope of the project, is a material change, or will otherwise require more compensation to the contractor, the contractor must immediately notify the City in writing of this belief. If the City believes that the particular work is within the scope of the contract as written, the contractor will be ordered to and shall continue with the work as changed and at the cost stated for the work within the scope.

**39. CONTRACTOR PERSONNEL:** The City of Naples shall, throughout the life of the contract, have the right of reasonable rejection and approval of staff or subcontractors assigned to the work by the contractor. If the City reasonably rejects staff or subcontractors, the contractor must provide replacement staff or subcontractors satisfactory to the City in a timely manner and at no additional cost to the City. The day-to-day supervision and control of the contractor's employees and sub-contractors is the responsibility solely of the contractor.

**40. COST REIMBURSEMENT:** The contractor agrees that all incidental costs, including allowances for profit and tools of the trade, must be included in the proposal rates. If an arrangement is made between the contractor and the City to reimburse the contractor for the cost of materials provided in the performance of the work, the contractor shall be reimbursed in the following manner: The City shall reimburse the contractor on completion and acceptance of each assigned job, only for those materials actually used in the performance of the work that is supported by invoices issued by the suppliers of the contractor describing the quantity and cost of the materials purchased. No surcharge shall be added to the supplier's invoices or included in the contractor's invoice submitted to the City that would increase the dollar amount indicated on the supplier's invoice for the materials purchased for the assigned job.

**41. EXCEPTIONS:** Proposers taking exception to any part or section of the solicitation shall indicate such exceptions on the proposal form. Failure to indicate any exception will be interpreted as the proposer's intent to comply fully with the requirements as written. Conditional or qualified proposals, unless specifically allowed, shall be subject to rejection in whole or in part.

**42. FAILURE TO DELIVER:** In the event of the contractor to fail to deliver services in accordance with the contract terms and conditions, the City, after due oral or written notice, may procure the services from other sources and hold the contractor responsible for any resulting purchase and administrative costs. This remedy shall be in addition to any other remedies that the City may have.

**43. FAILURE TO ENFORCE:** Failure by the City at any time to enforce the provisions of the contract shall not be construed as a waiver of any such provisions. Such failure to enforce shall not affect the validity of the contract or any part thereof or the right of the City to enforce any provision at any time in accordance with its terms.

**44. FORCE MAJEURE:** The contractor shall not be held responsible for failure to perform the duties and responsibilities imposed by the contract due to legal strikes, fires, riots, rebellions and acts of God beyond the control of the contractor, unless otherwise specified in the contract.

**45. INDEPENDENT CONTRACTOR:** The contractor shall be legally considered an independent contractor and neither the contractor nor its employees shall, under any circumstances, be considered servants or agents of the City of Naples and the City of Naples shall be at no time legally responsible for any negligence or any wrongdoing by the contractor, its servants or agents. The City of Naples shall not withhold from the contract payments to the contractor any federal income taxes, Social Security tax, or any other amounts for benefits to the contractor. Further, the City shall not provide to the contractor any insurance coverage or other benefits, including Workers' Compensation normally provided by the City for its employees.

**46. ORAL STATEMENTS:** No oral statement of any person shall modify or otherwise affect the terms, conditions or specifications stated in this contract. All modifications to the contract must be made in writing by the City of Naples.

**47. QUALIFICATIONS OF PROPOSERS:** The proposer may be required, before the award of any contract, to show to the complete satisfaction of the City of Naples that it has the necessary facilities, ability, and financial resources to provide the service specified therein in a satisfactory manner. The proposer may also be required to give a past history and references in order to satisfy the City in regard to the proposer's qualifications. The City may make reasonable investigations deemed necessary and proper to determine the ability of the proposer to perform the work, and the proposer shall furnish to the City all information for this purpose that may be requested. The City reserves the right to reject any proposal if the evidence submitted by, or investigation of, the proposer fails to satisfy the City that the proposer is properly qualified to carry out the obligations of the contract and to complete the work described therein. Evaluation of the proposer's qualifications shall include:

- > The ability, capacity, skill and financial resources to perform the work or service.
- > The ability to perform the work service promptly or within the time specified, without delay.
- > The character, integrity, reputation, judgment, experience, and efficiency of the proposer.
- > The quality of performance of previous contracts or services.

**48. QUALITY CONTROL:** The contractor shall institute and maintain throughout the contract period a properly documented quality control program designed to ensure that the services are provided at all times and in all respects in accordance with the contract. The program shall include providing daily supervision and conducting frequent inspections of the contractor's staff and ensuring that accurate records are maintained describing the disposition of all complaints. The records so created shall be open to inspection by the City.

**49. RECOVERY OF MONEY:** Whenever, under the contract, any sum of money shall be recoverable from or payable by the contractor to the City, the same amount may be deducted from any sum due to the contractor under the contract or under any other contract between the contractor and the City. The rights of the City are in addition and without prejudice to any other right the City may have to claim the amount of any loss or damage suffered by the City on account of the acts or omissions of the contractor.

**50. REQUIREMENTS CONTRACT:** During the period of the contract, the contractor shall provide all the services described in the contract. The contractor understands and agrees that this is a requirements contract and that the City shall have no obligation to the contractor if no services are required. Any quantities that are included in the scope of work reflect the current expectations of the City for the period of the contract. The amount is only an estimate and the contractor understands and agrees that the City is under no obligation to the contractor to buy any amount of services as a result of having provided this estimate or of having any typical or measurable requirement in the past. The contractor further understands and agrees that the City may require services in excess of the estimated annual contract amount and that the quantity actually used whether in excess of, or less than, the estimated annual contract amount and that the quantity actually used shall not give rise to any claim for compensation other than the total of the unit prices in the contract for the quantity actually used.

**51. TERMINATION FOR CONVENIENCE:** The performance of work under the contract may be terminated by the City in whole or in part whenever the City determines that termination is in the City's best interest. Any such termination shall be effected by the delivery to the contractor of a written notice of termination of at least seven (7) days before the date of termination, specifying the extent to which performance of the work under the contract is terminated and the date upon which such termination becomes effective. After receipt of a notice of termination, except as otherwise directed, the contractor shall stop work on the date of the receipt of the notice or other date specified in the notice; place no further orders or subcontracts for materials, services or facilities except as necessary for completion of such portion of the work not terminated; terminate all vendors and subcontracts; and settle all outstanding liabilities and claims.

**52. TERMINATION FOR DEFAULT:** The City of Naples reserves the right to terminate the contract if the City determines that the contractor has failed to perform satisfactorily the work required, as determined by the City. In the event the City decides to terminate the contract for failure to perform satisfactorily, the City shall give to the contractor at least seven (7) days written notice before the termination takes effect. The seven-day period will begin upon the mailing of notice by the City. If the contractor fails to cure the default within the seven (7) days specified in the notice and the contract is terminated for failure to perform satisfactorily, the contractor shall be entitled to receive compensation for all reasonable, allocable and allowable contract services satisfactorily performed by the contractor up to the date of termination that were accepted by the City prior to the termination. In the event the City terminates the contract because of the default of the contractor, the contractor shall be liable for all excess costs that the City is required to expend to complete the work under contract.

**53. STATE AND FEDERAL EMPLOYMENT LAWS:** Contractors providing service to the City are required to comply with all state and federal employment laws. This includes, but is not limited to, laws resulting from the Immigration and Reform and Control Act of 1986, wherein all employers are required to verify the identity and employment eligibility of all employees. The Department of Homeland Security, U.S. Citizenship and Immigration Services require employees and employers to complete Form I-9 and the employer must examine evidence of identity and employment eligibility within three business days of the date employment begins. Non compliant contractors will be subject to contract sanctions, up to and including contract termination.

**54. CERTIFICATION REGARDING DEBARMENT, SUSPENSION, INELIGIBILITY, AND VOLUNTARY EXCLUSION:** The contractor agrees to comply with Executive Order 12549 "Debarment and Suspension" and 2 CFR 180 "OMB Guidelines to Agencies on Government wide Debarment and Suspension." These rules require all contractors using federal funds not be debarred or suspended from doing business with the Federal Government. This includes sub-recipients and lower tier participant for covered transactions. Signing and submitting this document certified the organization and its principals are not presently debarred, suspended, proposed for debarment, declared ineligible, or voluntarily excluded from participation in this transaction by any federal department or agency, and further have not within the preceding three-year period been convicted of or had a civil judgment rendered against them for commission of fraud or a criminal offense in connection with obtaining, attempting to obtain, or performing a public (Federal, State or local) transaction.

**THE CITY OF NAPLES IS AN EQUAL OPPORTUNITY EMPLOYER**

## GENERAL INSURANCE REQUIREMENTS

The Contractor shall not commence work until he has obtained all the insurance required under this heading, and until such insurance has been approved by the Owner, nor shall the Contractor allow any subcontractor to commence work until all similar insurance required of the subcontractor has also been obtained and approved by the Owner.

Certificates of insurance must be issued by an authorized representative of the insurance company at the request and direction of the policyholder and must include sufficient information so as to identify the coverage and the contract for Owner's improvements for which they are issued. Certificates of insurance must be issued by a nationally recognized insurance company with a Best's Rating of no less than B+VII, satisfactory to the Owner, and duly licensed to do business in the state of said Contract.

The Contractor shall procure and maintain, during the life of this Contract, Workmen's Compensation Insurance for all of his employees to be engaged in work under this Contract, and he shall require any subcontractor similarly to provide Workmen's Compensation Insurance for all of the latter's employees to be engaged in such work, unless such employees are covered by the protection afforded by the Contractor's insurance. In case any employees are to be engaged in hazardous work under this Contract, and are not protected under this Workmen's Compensation statute, the Contractor shall provide, and shall cause each subcontractor to provide, adequate coverage for the protection of such employees. It is acceptable to use a State-approved Workmen's Compensation Self-Insurance fund.

The Contractor shall take out and maintain during the life of this Contract, Public Liability and Property Damage and shall include Contractual Liability, Personal Injury, Libel, Slander, False Arrest, Malicious Prosecution, Wrongful Entry or Eviction, Broad Form Property Damage, Products, Completed Operations and XCU Coverage to be included on an occurrence basis, and to the full extent of the Contract to protect him, the Owner, and any subcontractor performing work covered by this Contract from damages for personal injury, including accidental death, as well as from claims for property damage, which may arise from operations under this contract, whether such operations be by himself or by a subcontractor, or by anyone directly or indirectly employed by either of them. The Contractor shall also maintain automobile liability insurance including "non-owned and hired" coverage. The entire cost of this insurance shall be borne by the Contractor.

The amount of such insurance shall be no less than \$1,000,000 annual aggregate for bodily injury and property damage combined per occurrence.

The City of Naples must be named as Additional Insured on the insurance certificate and the following must also be stated on the certificate. "These coverage's are primary to all other coverage's the City possesses for this contract only." The City of Naples shall be named as the Certificate Holder. The Certificate Holder shall read as follows:

The City of Naples  
735 Eighth Street South  
Naples, Florida 34102

No City Division, Department, or individual name should appear on the Certificate.  
No other format will be acceptable.

The Certificate must state the solicitation number and title.

When using the ACORD 25 – Certificate of Insurance only the most current version will be accepted.

The City of Naples requires a copy of a cancellation notice in the event the policy is cancelled. The City of Naples shall be expressly endorsed onto the policy as a cancellation notice recipient.

**Proof of insurance from the successful proposer is required at the time of issuance and award of a contract.**

**STATEMENT OF NO BID**

**If you will not be bidding on this product/service, please help us by completing and returning only this page to:**

**City of Naples, Purchasing Division  
City Hall, 735 8<sup>th</sup> Street South  
Naples, FL 34102  
Fax 239-213-7105**

**Bid # \_\_\_\_\_ and Description: \_\_\_\_\_**

**We, the undersigned, decline to bid on the above project for the following reason(s):**

- We are not able to respond to the Invitation to Bid by the specified deadline.**
- Our Company does not offer this product or service.**
- Our current work schedule will not permit us to perform the required services.**
- Specifications are incomplete or information is unclear  
(Please explain below).**

\_\_\_\_\_  
\_\_\_\_\_

**Other (Please specify below)**

\_\_\_\_\_  
\_\_\_\_\_

**Company Name** \_\_\_\_\_

**PH** \_\_\_\_\_ **Email** \_\_\_\_\_

**Name and Title of individual completing this form:**

\_\_\_\_\_  
**(Printed Name)** **(Title)**

\_\_\_\_\_  
**(Signature)** **(Date)**

**REFERENCES**

**THIS SHEET MUST BE COMPLETED AND RETURNED WITH BID**

**PROVIDE AT LEAST THREE NON-CITY REFERENCES FOR WHOM YOUR COMPANY HAS PROVIDED SAME OR SIMILAR SERVICES WITHIN THE LAST 2 YEARS.**

**COMPANY NAME:** \_\_\_\_\_

**ADDRESS:** \_\_\_\_\_

**TELEPHONE:** \_\_\_\_\_

**CONTACT PERSON:** \_\_\_\_\_

**CONTACT E-MAIL ADDRESS:** \_\_\_\_\_

**COMPANY NAME:** \_\_\_\_\_

**ADDRESS:** \_\_\_\_\_

**TELEPHONE:** \_\_\_\_\_

**CONTACT PERSON:** \_\_\_\_\_

**CONTACT E-MAIL ADDRESS:** \_\_\_\_\_

**COMPANY NAME:** \_\_\_\_\_

**ADDRESS:** \_\_\_\_\_

**TELEPHONE:** \_\_\_\_\_

**CONTACT PERSON:** \_\_\_\_\_

**CONTACT E-MAIL ADDRESS:** \_\_\_\_\_

**Submitting Vendor Name:** \_\_\_\_\_

ACQUISITIONS  
SPECIAL CONDITIONS

- A. **TERMS OF CONTRACT:** The resulting contract will commence on award and be in effect until completion of the project. The resultant contract will include the federal provisions found in Attachment A. Prices established by this bid shall be honored for a minimum of 24-months from the date the Agreement is executed by the City. The Contractor shall honor any order made by the City for any amount of decorative sign assemblies as allowed for by these specifications and at the rates set forth in the Bid Tabulation for a period of 12-months after the City's execution date of the Agreement. At the conclusion of the term of Agreement, the City and Contractor shall each have the option to extend the term of Agreement for two additional 12-month periods. As a method to assure completion of the total project, retainage in the amount of ten percent (10%) of all work completed will be withheld from the payment. The retainage will be released upon final inspection and project completion. Retention is required for any contract over \$200,000.
- B. **PROHIBITION OF CONTACT:** Under no circumstances should any prospective organization or individual, or anyone acting for or on behalf of a prospective organization or individual, seek to influence or gain the support of any member of the City Council, public official or City staff favorable to the interest of any prospective organization or individual. Likewise, contact with City Council, any public official or city staff against the interests of other prospective organization (s) and or individual(s) is prohibited. Any such activities will result in the exclusion of the prospective organization or individual from consideration by the City.
- C. **REFERENCES:** Bidder must submit a minimum of three references on the form provided. Additionally, a completed IRS W-9 form is required with the bid submission.
- D. **STATEMENT OF NO BID:** If you will not be bidding on this producer/service, please help us by completing and returning the Statement of No Bid.
- E. **BID FORMAT**  
The Contract, if awarded, will be awarded on the basis of material and installation illustrated and described on the Drawings or specified in the Specification. If a substitution or an "or equal" item is proposed, Proposer must submit this information to the City of Naples Purchasing Department ten (10) days prior to the bid opening date for evaluation as an acceptable substitution or an "or equal" item. If the substitution or the "or equal" item is accepted, the City of Naples will issue an Addendum to all Proposers listing the allowable substitution or the "or equal" item. The cost of changes in related work, additional drawings which may be required to illustrate or define the substitute or "or equal" equipment and its relationship to the other parts or portions of the Work shall be paid by the Contractor. No change will be made in the amount of time in which to complete the Work.
- F. **QUESTIONS:** Questions regarding this proposer packet must be received in writing in the Purchasing Division, **NO LATER THAN TEN CALENDAR DAYS**

PRIOR TO THE PROPOSAL OPENING DATE TO ENSURE AN ANSWER IS PROVIDED PRIOR TO CLOSING.

**Direct all questions to:**

Gerald "Jed" Secory, MBA / CPPO / CPM  
Purchasing Manager  
City of Naples, Purchasing Division  
735 8th Street South  
Naples, Florida 34102  
PH: (239) 213-7102 FX: (239) 213-7105  
[Jsecory@naplesgov.com](mailto:Jsecory@naplesgov.com)



## SUBMISSION CHECKLIST

Bidder should check off each of the following items as completed and submit with bid response:

CHECKLIST ELEMENTS	INCLUDED
<ul style="list-style-type: none"> <li>Submit one (1) original signature and one (1) copy of your original bid / document AND a Windows© compatible PDF of the original document on a CD or Flash / Thumb Drive that is clearly labeled.</li> </ul>	<input type="checkbox"/>
<ul style="list-style-type: none"> <li>Include any required drawings; descriptive literature; qualifications; schedules; product compliance / exceptions; alternatives; questionnaire; references, forms, tabs, pricing/cost; and any information required of the proposer identified in the text of the bid including information for bid evaluation.</li> </ul>	<input type="checkbox"/>
<ul style="list-style-type: none"> <li>Include any Professional Licenses that qualify the firm for this solicitation as well as applicable bond documents, if required. Note if you are not a single prime contractor. List all subcontractors to be used for our project in your bid/proposal and their professional licenses.</li> </ul>	<input type="checkbox"/>
<ul style="list-style-type: none"> <li>Mandatory FORMS from this document to be included are: <u>Cover Sheet</u>, <u>References Sheet</u>, <u>Submission Checklist Sheet</u>, <u>IRS W-9</u> (Dec 2014) and <u>Cost / Price Schedule</u>.</li> </ul>	<input type="checkbox"/>
<ul style="list-style-type: none"> <li>Have an authorized individual sign the appropriate pages including the <u>Cover Sheet</u> with bid addenda initialed.</li> </ul>	<input type="checkbox"/>
<ul style="list-style-type: none"> <li>Bid document needs to be received by the OPENING DATE &amp; TIME indicated on the Cover Sheet. The mailing envelope must be addressed to:   <div style="text-align: center;">                     City of Naples                      Purchasing Division                      735 8<sup>th</sup> Street South                      Naples, Florida 34102                 </div> </li> </ul>	<input type="checkbox"/>
<p style="text-align: center;">The mailing envelope should be sealed and marked with:</p> <p>Number:           <b>18-015</b>                      Title:               <b>Decorative Street Signs</b>                      Opening Date:   <b>1/11/2018</b></p>	<input type="checkbox"/>

ALL COURIER DELIVERED BIDS MUST HAVE THE BID NUMBER AND TITLE ON THE OUTSIDE OF THE COURIER PACKET.

Submitting Vendor Name: \_\_\_\_\_

*At the discretion of the Purchasing Manager, bids or proposals with minor irregularities may be accepted and allowed to be corrected when in the best interest of the City.*

W-9 FORM MUST BE COMPLETED AND RETURNED WITH BID

Fillable Form can also be downloaded at
https://www.irs.gov/pub/irs-pdf/fw9.pdf

Form W-9
(Rev. December 2014)
Department of the Treasury
Internal Revenue Service

Request for Taxpayer
Identification Number and Certification

Give Form to the
requester. Do not
send to the IRS.

1 Name (as shown on your income tax return). Name is required on this line; do not leave this line blank.
2 Business name/disregarded entity name, if different from above
3 Check appropriate box for federal tax classification; check only one of the following seven boxes:
4 Exemptions (codes apply only to certain entities, not individuals; see instructions on page 3):
5 Address (number, street, and apt. or suite no.)
6 City, state, and ZIP code
7 List account number(s) here (optional)

Part I Taxpayer Identification Number (TIN)

Enter your TIN in the appropriate box. The TIN provided must match the name given on line 1 to avoid backup withholding. For individuals, this is generally your social security number (SSN). However, for a resident alien, sole proprietor, or disregarded entity, see the Part I instructions on page 3. For other entities, it is your employer identification number (EIN). If you do not have a number, see How to get a TIN on page 3.

Social security number
Employer identification number

Note. If the account is in more than one name, see the instructions for line 1 and the chart on page 4 for guidelines on whose number to enter.

Part II Certification

Under penalties of perjury, I certify that:

- 1. The number shown on this form is my correct taxpayer identification number (or I am waiting for a number to be issued to me); and
2. I am not subject to backup withholding because: (a) I am exempt from backup withholding, or (b) I have not been notified by the Internal Revenue Service (IRS) that I am subject to backup withholding as a result of a failure to report all interest or dividends, or (c) the IRS has notified me that I am no longer subject to backup withholding; and
3. I am a U.S. citizen or other U.S. person (defined below); and
4. The FATCA code(s) entered on this form (if any) indicating that I am exempt from FATCA reporting is correct.

Certification instructions. You must cross out item 2 above if you have been notified by the IRS that you are currently subject to backup withholding because you have failed to report all interest and dividends on your tax return. For real estate transactions, item 2 does not apply. For mortgage interest paid, acquisition or abandonment of secured property, cancellation of debt, contributions to an individual retirement arrangement (IRA), and generally, payments other than interest and dividends, you are not required to sign the certification, but you must provide your correct TIN. See the instructions on page 3.

Sign Here
Signature of U.S. person
Date

General Instructions

Section references are to the Internal Revenue Code unless otherwise noted.

Future developments. Information about developments affecting Form W-9 (such as legislation enacted after we release it) is at www.irs.gov/fw9.

Purpose of Form

An individual or entity (Form W-9 requester) who is required to file an information return with the IRS must obtain your correct taxpayer identification number (TIN) which may be your social security number (SSN), individual taxpayer identification number (ITIN), adoption taxpayer identification number (ATIN), or employer identification number (EIN), to report on an information return the amount paid to you, or other amount reportable on an information return. Examples of information returns include, but are not limited to, the following:

- Form 1099-INT (interest earned or paid)
• Form 1099-DIV (dividends, including those from stocks or mutual funds)
• Form 1099-MISC (various types of income, prizes, awards, or gross proceeds)
• Form 1099-B (stock or mutual fund sales and certain other transactions by brokers)
• Form 1099-S (proceeds from real estate transactions)
• Form 1099-K (merchant card and third party network transactions)

- Form 1098 (home mortgage interest), 1098-E (student loan interest), 1098-T (tuition)
• Form 1099-C (canceled debt)
• Form 1099-A (acquisition or abandonment of secured property)

Use Form W-9 only if you are a U.S. person (including a resident alien), to provide your correct TIN.

If you do not return Form W-9 to the requester with a TIN, you might be subject to backup withholding. See What is backup withholding? on page 2.

By signing the filled-out form, you:

- 1. Certify that the TIN you are giving is correct (or you are waiting for a number to be issued),
2. Certify that you are not subject to backup withholding, or
3. Claim exemption from backup withholding if you are a U.S. exempt payee. If applicable, you are also certifying that as a U.S. person, your allocable share of any partnership income from a U.S. trade or business is not subject to the withholding tax on foreign partners' share of effectively connected income, and
4. Certify that FATCA code(s) entered on this form (if any) indicating that you are exempt from the FATCA reporting, is correct. See What is FATCA reporting? on page 2 for further information.

**Note.** If you are a U.S. person and a requester gives you a form other than Form W-9 to request your TIN, you must use the requester's form if it is substantially similar to this Form W-9.

**Definition of a U.S. person.** For federal tax purposes, you are considered a U.S. person if you are:

- An individual who is a U.S. citizen or U.S. resident alien;
- A partnership, corporation, company, or association created or organized in the United States or under the laws of the United States;
- An estate (other than a foreign estate); or
- A domestic trust (as defined in Regulations section 301.7701-7).

**Special rules for partnerships.** Partnerships that conduct a trade or business in the United States are generally required to pay a withholding tax under section 1446 on any foreign partners' share of effectively connected taxable income from such business. Further, in certain cases where a Form W-9 has not been received, the rules under section 1446 require a partnership to presume that a partner is a foreign person, and pay the section 1446 withholding tax. Therefore, if you are a U.S. person that is a partner in a partnership conducting a trade or business in the United States, provide Form W-9 to the partnership to establish your U.S. status and avoid section 1446 withholding on your share of partnership income.

In the cases below, the following person must give Form W-9 to the partnership for purposes of establishing its U.S. status and avoiding withholding on its allocable share of net income from the partnership conducting a trade or business in the United States:

- In the case of a disregarded entity with a U.S. owner, the U.S. owner of the disregarded entity and not the entity;
- In the case of a grantor trust with a U.S. grantor or other U.S. owner, generally, the U.S. grantor or other U.S. owner of the grantor trust and not the trust; and
- In the case of a U.S. trust (other than a grantor trust), the U.S. trust (other than a grantor trust) and not the beneficiaries of the trust.

**Foreign person.** If you are a foreign person or the U.S. branch of a foreign bank that has elected to be treated as a U.S. person, do not use Form W-9. Instead, use the appropriate Form W-8 or Form 8233 (see Publication 515, Withholding of Tax on Nonresident Aliens and Foreign Entities).

**Nonresident alien who becomes a resident alien.** Generally, only a nonresident alien individual may use the terms of a tax treaty to reduce or eliminate U.S. tax on certain types of income. However, most tax treaties contain a provision known as a "saving clause." Exceptions specified in the saving clause may permit an exemption from tax to continue for certain types of income even after the payee has otherwise become a U.S. resident alien for tax purposes.

If you are a U.S. resident alien who is relying on an exception contained in the saving clause of a tax treaty to claim an exemption from U.S. tax on certain types of income, you must attach a statement to Form W-9 that specifies the following five items:

1. The treaty country. Generally, this must be the same treaty under which you claimed exemption from tax as a nonresident alien.
2. The treaty article addressing the income.
3. The article number (or location) in the tax treaty that contains the saving clause and its exceptions.
4. The type and amount of income that qualifies for the exemption from tax.
5. Sufficient facts to justify the exemption from tax under the terms of the treaty article.

**Example.** Article 20 of the U.S.-China income tax treaty allows an exemption from tax for scholarship income received by a Chinese student temporarily present in the United States. Under U.S. law, this student will become a resident alien for tax purposes if his or her stay in the United States exceeds 5 calendar years. However, paragraph 2 of the first Protocol to the U.S.-China treaty (dated April 30, 1984) allows the provisions of Article 20 to continue to apply even after the Chinese student becomes a resident alien of the United States. A Chinese student who qualifies for this exception (under paragraph 2 of the first protocol) and is relying on this exception to claim an exemption from tax on his or her scholarship or fellowship income would attach to Form W-9 a statement that includes the information described above to support that exemption.

If you are a nonresident alien or a foreign entity, give the requester the appropriate completed Form W-8 or Form 8233.

## Backup Withholding

**What is backup withholding?** Persons making certain payments to you must under certain conditions withhold and pay to the IRS 28% of such payments. This is called "backup withholding." Payments that may be subject to backup withholding include interest, tax-exempt interest, dividends, broker and barter exchange transactions, rents, royalties, nonemployee pay, payments made in settlement of payment card and third party network transactions, and certain payments from fishing boat operators. Real estate transactions are not subject to backup withholding.

You will not be subject to backup withholding on payments you receive if you give the requester your correct TIN, make the proper certifications, and report all your taxable interest and dividends on your tax return.

**Payments you receive will be subject to backup withholding if:**

1. You do not furnish your TIN to the requester,
2. You do not certify your TIN when required (see the Part II instructions on page 3 for details),

3. The IRS tells the requester that you furnished an incorrect TIN,

4. The IRS tells you that you are subject to backup withholding because you did not report all your interest and dividends on your tax return (for reportable interest and dividends only), or

5. You do not certify to the requester that you are not subject to backup withholding under 4 above (for reportable interest and dividend accounts opened after 1983 only).

Certain payees and payments are exempt from backup withholding. See *Exempt payee code* on page 3 and the separate Instructions for the Requester of Form W-9 for more information.

Also see *Special rules for partnerships* above.

## What is FATCA reporting?

The Foreign Account Tax Compliance Act (FATCA) requires a participating foreign financial institution to report all United States account holders that are specified United States persons. Certain payees are exempt from FATCA reporting. See *Exemption from FATCA reporting code* on page 3 and the Instructions for the Requester of Form W-9 for more information.

## Updating Your Information

You must provide updated information to any person to whom you claimed to be an exempt payee if you are no longer an exempt payee and anticipate receiving reportable payments in the future from this person. For example, you may need to provide updated information if you are a C corporation that elects to be an S corporation, or if you no longer are tax exempt. In addition, you must furnish a new Form W-9 if the name or TIN changes for the account; for example, if the grantor of a grantor trust dies.

## Penalties

**Failure to furnish TIN.** If you fail to furnish your correct TIN to a requester, you are subject to a penalty of \$50 for each such failure unless your failure is due to reasonable cause and not to willful neglect.

**Civil penalty for false information with respect to withholding.** If you make a false statement with no reasonable basis that results in no backup withholding, you are subject to a \$500 penalty.

**Criminal penalty for falsifying information.** Willfully falsifying certifications or affirmations may subject you to criminal penalties including fines and/or imprisonment.

**Misuse of TINs.** If the requester discloses or uses TINs in violation of federal law, the requester may be subject to civil and criminal penalties.

## Specific Instructions

### Line 1

You must enter one of the following on this line; **do not** leave this line blank. The name should match the name on your tax return.

If this Form W-9 is for a joint account, list first, and then circle, the name of the person or entity whose number you entered in Part I of Form W-9.

**a. Individual.** Generally, enter the name shown on your tax return. If you have changed your last name without informing the Social Security Administration (SSA) of the name change, enter your first name, the last name as shown on your social security card, and your new last name.

**Note. ITIN applicant:** Enter your individual name as it was entered on your Form W-7 application, line 1a. This should also be the same as the name you entered on the Form 1040/1040A/1040EZ you filed with your application.

**b. Sole proprietor or single-member LLC.** Enter your individual name as shown on your 1040/1040A/1040EZ on line 1. You may enter your business, trade, or "doing business as" (DBA) name on line 2.

**c. Partnership, LLC that is not a single-member LLC, C Corporation, or S Corporation.** Enter the entity's name as shown on the entity's tax return on line 1 and any business, trade, or DBA name on line 2.

**d. Other entities.** Enter your name as shown on required U.S. federal tax documents on line 1. This name should match the name shown on the charter or other legal document creating the entity. You may enter any business, trade, or DBA name on line 2.

**e. Disregarded entity.** For U.S. federal tax purposes, an entity that is disregarded as an entity separate from its owner is treated as a "disregarded entity." See Regulations section 301.7701-2(c)(2)(iii). Enter the owner's name on line 1. The name of the entity entered on line 1 should never be a disregarded entity. The name on line 1 should be the name shown on the income tax return on which the income should be reported. For example, if a foreign LLC that is treated as a disregarded entity for U.S. federal tax purposes has a single owner that is a U.S. person, the U.S. owner's name is required to be provided on line 1. If the direct owner of the entity is also a disregarded entity, enter the first owner that is not disregarded for federal tax purposes. Enter the disregarded entity's name on line 2, "Business name/disregarded entity name." If the owner of the disregarded entity is a foreign person, the owner must complete an appropriate Form W-8 instead of a Form W-9. This is the case even if the foreign person has a U.S. TIN.

**Line 2**

If you have a business name, trade name, DBA name, or disregarded entity name, you may enter it on line 2.

**Line 3**

Check the appropriate box in line 3 for the U.S. federal tax classification of the person whose name is entered on line 1. Check only one box in line 3.

**Limited Liability Company (LLC).** If the name on line 1 is an LLC treated as a partnership for U.S. federal tax purposes, check the "Limited Liability Company" box and enter "P" in the space provided. If the LLC has filed Form 8832 or 2553 to be taxed as a corporation, check the "Limited Liability Company" box and in the space provided enter "C" for C corporation or "S" for S corporation. If it is a single-member LLC that is a disregarded entity, do not check the "Limited Liability Company" box; instead check the first box in line 3 "Individual/sole proprietor or single-member LLC."

**Line 4, Exemptions**

If you are exempt from backup withholding and/or FATCA reporting, enter in the appropriate space in line 4 any code(s) that may apply to you.

**Exempt payee code.**

- Generally, individuals (including sole proprietors) are not exempt from backup withholding.
- Except as provided below, corporations are exempt from backup withholding for certain payments, including interest and dividends.
- Corporations are not exempt from backup withholding for payments made in settlement of payment card or third party network transactions.
- Corporations are not exempt from backup withholding with respect to attorneys' fees or gross proceeds paid to attorneys, and corporations that provide medical or health care services are not exempt with respect to payments reportable on Form 1099-MISC.

The following codes identify payees that are exempt from backup withholding. Enter the appropriate code in the space in line 4.

- 1—An organization exempt from tax under section 501(a), any IRA, or a custodial account under section 403(b)(7) if the account satisfies the requirements of section 401(f)(2)
- 2—The United States or any of its agencies or instrumentalities
- 3—A state, the District of Columbia, a U.S. commonwealth or possession, or any of their political subdivisions or instrumentalities
- 4—A foreign government or any of its political subdivisions, agencies, or instrumentalities
- 5—A corporation
- 6—A dealer in securities or commodities required to register in the United States, the District of Columbia, or a U.S. commonwealth or possession
- 7—A futures commission merchant registered with the Commodity Futures Trading Commission
- 8—A real estate investment trust
- 9—An entity registered at all times during the tax year under the Investment Company Act of 1940
- 10—A common trust fund operated by a bank under section 584(a)
- 11—A financial institution
- 12—A middleman known in the investment community as a nominee or custodian
- 13—A trust exempt from tax under section 664 or described in section 4947

The following chart shows types of payments that may be exempt from backup withholding. The chart applies to the exempt payees listed above, 1 through 13.

IF the payment is for . . .	THEN the payment is exempt for . . .
Interest and dividend payments	All exempt payees except for 7
Broker transactions	Exempt payees 1 through 4 and 6 through 11 and all C corporations. S corporations must not enter an exempt payee code because they are exempt only for sales of noncovered securities acquired prior to 2012.
Barter exchange transactions and patronage dividends	Exempt payees 1 through 4
Payments over \$600 required to be reported and direct sales over \$5,000 <sup>1</sup>	Generally, exempt payees 1 through 5 <sup>2</sup>
Payments made in settlement of payment card or third party network transactions	Exempt payees 1 through 4

<sup>1</sup> See Form 1099-MISC, Miscellaneous Income, and its instructions.

<sup>2</sup> However, the following payments made to a corporation and reportable on Form 1099-MISC are not exempt from backup withholding: medical and health care payments, attorneys' fees, gross proceeds paid to an attorney reportable under section 6045(f), and payments for services paid by a federal executive agency.

**Exemption from FATCA reporting code.** The following codes identify payees that are exempt from reporting under FATCA. These codes apply to persons submitting this form for accounts maintained outside of the United States by certain foreign financial institutions. Therefore, if you are only submitting this form for an account you hold in the United States, you may leave this field blank. Consult with the person requesting this form if you are uncertain if the financial institution is subject to these requirements. A requester may indicate that a code is not required by providing you with a Form W-9 with "Not Applicable" (or any similar indication) written or printed on the line for a FATCA exemption code.

- A—An organization exempt from tax under section 501(a) or any individual retirement plan as defined in section 7701(a)(37)
- B—The United States or any of its agencies or instrumentalities
- C—A state, the District of Columbia, a U.S. commonwealth or possession, or any of their political subdivisions or instrumentalities
- D—A corporation the stock of which is regularly traded on one or more established securities markets, as described in Regulations section 1.1472-1(c)(1)(i)
- E—A corporation that is a member of the same expanded affiliated group as a corporation described in Regulations section 1.1472-1(c)(1)(i)
- F—A dealer in securities, commodities, or derivative financial instruments (including notional principal contracts, futures, forwards, and options) that is registered as such under the laws of the United States or any state
- G—A real estate investment trust
- H—A regulated investment company as defined in section 851 or an entity registered at all times during the tax year under the Investment Company Act of 1940
- I—A common trust fund as defined in section 584(a)
- J—A bank as defined in section 581
- K—A broker
- L—A trust exempt from tax under section 664 or described in section 4947(a)(1)
- M—A tax exempt trust under a section 403(b) plan or section 457(g) plan

**Note.** You may wish to consult with the financial institution requesting this form to determine whether the FATCA code and/or exempt payee code should be completed.

**Line 5**

Enter your address (number, street, and apartment or suite number). This is where the requester of this Form W-9 will mail your information returns.

**Line 6**

Enter your city, state, and ZIP code.

**Part I. Taxpayer Identification Number (TIN)**

**Enter your TIN in the appropriate box.** If you are a resident alien and you do not have and are not eligible to get an SSN, your TIN is your IRS individual taxpayer identification number (ITIN). Enter it in the social security number box. If you do not have an ITIN, see *How to get a TIN* below.

If you are a sole proprietor and you have an EIN, you may enter either your SSN or EIN. However, the IRS prefers that you use your SSN.

If you are a single-member LLC that is disregarded as an entity separate from its owner (see *Limited Liability Company (LLC)* on this page), enter the owner's SSN (or EIN, if the owner has one). Do not enter the disregarded entity's EIN. If the LLC is classified as a corporation or partnership, enter the entity's EIN.

**Note.** See the chart on page 4 for further clarification of name and TIN combinations.

**How to get a TIN.** If you do not have a TIN, apply for one immediately. To apply for an SSN, get Form SS-5, Application for a Social Security Card, from your local SSA office or get this form online at [www.ssa.gov](http://www.ssa.gov). You may also get this form by calling 1-800-772-1213. Use Form W-7, Application for IRS Individual Taxpayer Identification Number, to apply for an ITIN, or Form SS-4, Application for Employer Identification Number, to apply for an EIN. You can apply for an EIN online by accessing the IRS website at [www.irs.gov/businesses](http://www.irs.gov/businesses) and clicking on Employer Identification Number (EIN) under Starting a Business. You can get Forms W-7 and SS-4 from the IRS by visiting [IRS.gov](http://IRS.gov) or by calling 1-800-TAX-FORM (1-800-829-3676).

If you are asked to complete Form W-9 but do not have a TIN, apply for a TIN and write "Applied For" in the space for the TIN, sign and date the form, and give it to the requester. For interest and dividend payments, and certain payments made with respect to readily tradable instruments, generally you will have 60 days to get a TIN and give it to the requester before you are subject to backup withholding on payments. The 60-day rule does not apply to other types of payments. You will be subject to backup withholding on all such payments until you provide your TIN to the requester.

**Note.** Entering "Applied For" means that you have already applied for a TIN or that you intend to apply for one soon.

**Caution:** A disregarded U.S. entity that has a foreign owner must use the appropriate Form W-8.



**Part II. Certification**

To establish to the withholding agent that you are a U.S. person, or resident alien, sign Form W-9. You may be requested to sign by the withholding agent even if items 1, 4, or 5 below indicate otherwise.

For a joint account, only the person whose TIN is shown in Part I should sign (when required). In the case of a disregarded entity, the person identified on line 1 must sign. Exempt payees, see *Exempt payee code* earlier.

**Signature requirements.** Complete the certification as indicated in items 1 through 5 below.

1. **Interest, dividend, and barter exchange accounts opened before 1984 and broker accounts considered active during 1983.** You must give your correct TIN, but you do not have to sign the certification.
2. **Interest, dividend, broker, and barter exchange accounts opened after 1983 and broker accounts considered inactive during 1983.** You must sign the certification or backup withholding will apply. If you are subject to backup withholding and you are merely providing your correct TIN to the requester, you must cross out item 2 in the certification before signing the form.
3. **Real estate transactions.** You must sign the certification. You may cross out item 2 of the certification.
4. **Other payments.** You must give your correct TIN, but you do not have to sign the certification unless you have been notified that you have previously given an incorrect TIN. "Other payments" include payments made in the course of the requester's trade or business for rents, royalties, goods (other than bills for merchandise), medical and health care services (including payments to corporations), payments to a nonemployee for services, payments made in settlement of payment card and third party network transactions, payments to certain fishing boat crew members and fishermen, and gross proceeds paid to attorneys (including payments to corporations).
5. **Mortgage interest paid by you, acquisition or abandonment of secured property, cancellation of debt, qualified tuition program payments (under section 529), IRA, Coverdell ESA, Archer MSA or HSA contributions or distributions, and pension distributions.** You must give your correct TIN, but you do not have to sign the certification.

**What Name and Number To Give the Requester**

For this type of account:	Give name and SSN of:
1. Individual	The individual
2. Two or more individuals (joint account)	The actual owner of the account or, if combined funds, the first individual on the account <sup>1</sup>
3. Custodian account of a minor (Uniform Gift to Minors Act)	The minor <sup>2</sup>
4. a. The usual revocable savings trust (grantor is also trustee) b. So-called trust account that is not a legal or valid trust under state law	The grantor-trustee <sup>1</sup> The actual owner <sup>1</sup>
5. Sole proprietorship or disregarded entity owned by an individual	The owner <sup>3</sup>
6. Grantor trust filing under Optional Form 1099 Filing Method 1 (see Regulations section 1.671-4(b)(2)(i)(A))	The grantor <sup>4</sup>
For this type of account:	Give name and EIN of:
7. Disregarded entity not owned by an individual	The owner
8. A valid trust, estate, or pension trust	Legal entity <sup>4</sup>
9. Corporation or LLC electing corporate status on Form 8832 or Form 2553	The corporation
10. Association, club, religious, charitable, educational, or other tax-exempt organization	The organization
11. Partnership or multi-member LLC	The partnership
12. A broker or registered nominee	The broker or nominee
13. Account with the Department of Agriculture in the name of a public entity (such as a state or local government, school district, or prison) that receives agricultural program payments	The public entity
14. Grantor trust filing under the Form 1041 Filing Method or the Optional Form 1099 Filing Method 2 (see Regulations section 1.671-4(b)(2)(i)(B))	The trust

<sup>1</sup> List first and circle the name of the person whose number you furnish. If only one person on a joint account has an SSN, that person's number must be furnished.

<sup>2</sup> Circle the minor's name and furnish the minor's SSN.

<sup>3</sup> You must show your individual name and you may also enter your business or DBA name on the "Business name/disregarded entity" name line. You may use either your SSN or EIN (if you have one), but the IRS encourages you to use your SSN.

<sup>4</sup> List first and circle the name of the trust, estate, or pension trust. (Do not furnish the TIN of the personal representative or trustee unless the legal entity itself is not designated in the account title.) Also see *Special rules for partnerships* on page 2.

**\*Note.** Grantor also must provide a Form W-9 to trustee of trust.

**Note.** If no name is circled when more than one name is listed, the number will be considered to be that of the first name listed.

**Secure Your Tax Records from Identity Theft**

Identity theft occurs when someone uses your personal information such as your name, SSN, or other identifying information, without your permission, to commit fraud or other crimes. An identity thief may use your SSN to get a job or may file a tax return using your SSN to receive a refund.

To reduce your risk:

- Protect your SSN,
- Ensure your employer is protecting your SSN, and
- Be careful when choosing a tax preparer.

If your tax records are affected by identity theft and you receive a notice from the IRS, respond right away to the name and phone number printed on the IRS notice or letter.

If your tax records are not currently affected by identity theft but you think you are at risk due to a lost or stolen purse or wallet, questionable credit card activity or credit report, contact the IRS Identity Theft Hotline at 1-800-908-4490 or submit Form 14039.

For more information, see Publication 4535, Identity Theft Prevention and Victim Assistance.

Victims of identity theft who are experiencing economic harm or a system problem, or are seeking help in resolving tax problems that have not been resolved through normal channels, may be eligible for Taxpayer Advocate Service (TAS) assistance. You can reach TAS by calling the TAS toll-free case intake line at 1-877-777-4778 or TTY/TDD 1-800-829-4059.

**Protect yourself from suspicious emails or phishing schemes.** Phishing is the creation and use of email and websites designed to mimic legitimate business emails and websites. The most common act is sending an email to a user falsely claiming to be an established legitimate enterprise in an attempt to scam the user into surrendering private information that will be used for identity theft.

The IRS does not initiate contacts with taxpayers via emails. Also, the IRS does not request personal detailed information through email or ask taxpayers for the PIN numbers, passwords, or similar secret access information for their credit card, bank, or other financial accounts.

If you receive an unsolicited email claiming to be from the IRS, forward this message to [phishing@irs.gov](mailto:phishing@irs.gov). You may also report misuse of the IRS name, logo, or other IRS property to the Treasury Inspector General for Tax Administration (TIGTA) at 1-800-366-4484. You can forward suspicious emails to the Federal Trade Commission at: [spam@uce.gov](mailto:spam@uce.gov) or contact them at [www.ftc.gov/idtheft](http://www.ftc.gov/idtheft) or 1-877-IDTHEFT (1-877-438-4338).

Visit [IRS.gov](http://IRS.gov) to learn more about identity theft and how to reduce your risk.

**Privacy Act Notice**

Section 6109 of the Internal Revenue Code requires you to provide your correct TIN to persons (including federal agencies) who are required to file information returns with the IRS to report interest, dividends, or certain other income paid to you; mortgage interest you paid; the acquisition or abandonment of secured property; the cancellation of debt; or contributions you made to an IRA, Archer MSA, or HSA. The person collecting this form uses the information on the form to file information returns with the IRS, reporting the above information. Routine uses of this information include giving it to the Department of Justice for civil and criminal litigation and to cities, states, the District of Columbia, and U.S. commonwealths and possessions for use in administering their laws. The information also may be disclosed to other countries under a treaty, to federal and state agencies to enforce civil and criminal laws, or to federal law enforcement and intelligence agencies to combat terrorism. You must provide your TIN whether or not you are required to file a tax return. Under section 3406, payers must generally withhold a percentage of taxable interest, dividend, and certain other payments to a payee who does not give a TIN to the payer. Certain penalties may also apply for providing false or fraudulent information.

# City of Naples FL

## Invitation to Bid

### 18-015 Decorative Street Signs

This project has potential for Federal Emergency Management Agency (FEMA) reimbursement and is subject to federal guidelines.

#### INDEX

		PAGE
COVER SHEET	REQUIRED	1
GENERAL CONDITIONS		2
GENERAL INSURANCE REQUIREMENTS		9
STATEMENT OF NO BID		10
REFERENCES	REQUIRED	11
SPECIAL CONDITIONS		12
SUBMISSION CHECKLIST	REQUIRED	13
IRS W-9 FORM	REQUIRED	14
<b>SPECIFICATIONS</b>		
PROJECT OVERVIEW		19
POST SPECIFICATIONS		
DECORATIVE COMPONENTS		
WELDING		
COATING AND COLOR		
INSTALLATION AND REMOVAL		
ACCEPTANCE		
PURCHASING REQUIREMENTS		
PRICE SCHEDULE	REQUIRED	28

#### Attachment A - FEMA Contract Procurement Provisions

# City of Naples FL

## Invitation to Bid

### 18-015 Decorative Street Signs

This project has potential for Federal Emergency Management Agency (FEMA) reimbursement and is subject to federal guidelines.

#### Project Overview

The purpose of this invitation to bid is to identify a potential responsive contractor to supply and install fully assembled decorative street and traffic signs. This project has potential for Federal Emergency Management Agency (FEMA) reimbursement and is subject to federal guidelines (refer to Attachment A).

#### 1) Post Specifications

- a) Street posts shall have a 4" O.D. (Outside Diameter) and have a minimum thickness of 0.125". See Detail #6.
- b) The City wishes to have two different post lengths – 13', 15'. The 13' and 15' posts will be direct bury.
- c) Post length shall allow for 80" (see price schedule for all post lengths) from concrete foundation mounting to bottom of regulatory sign frame. The concrete foundation shall rise out of the ground and have an elevation of no less than 2.5" from the natural ground surface and no more than 3.5" from ground surface. The sign frame shall be 1" thick around the entire sign. Therefore, the sign, as mounted, shall have between 83.5" and 84.5" between natural ground surface and the bottom of the sign.
- d) Street posts shall be fluted and made of extruded aluminum.
- e) **Technical requirements must be verified by City with submittal of cut sheets and/or technical specifications. In the best interest of the City, the City reserves the right to consider alternative design options, dimensions, fabrication methods, assembly methods or any other variations as proposed by the manufacturer. Alternative design options must be signed and sealed by an engineer to meet 180 MPH wind speeds.**
- f) Horizontal clearances and offsets from edge of pavement, sidewalks, crosswalks, etc. shall meet criteria set forth by M.U.T.C.D. In accordance with Florida law, the Contractor shall call Florida Sunshine One to locate utilities prior to digging. Prior to installation, the Contractor shall identify the actual field location for each sign with the City's designated inspector. No sign shall be erected without the prior approval of the City inspector.

#### 2) Decorative Components: Sign Frame, Finial, Base, Scroll, Street Name Flags

- a) **Sign Frame & Backing**: The sign frame shall be made from a single piece of cast aluminum and be bolted to an aluminum mounting bracket that is welded to the fluted aluminum post. An example of the sign frame backing is shown in Detail #7.
- b) **Finial**: Decorative finial caps shall be cast aluminum, be an "Acorn" design, and be made for and welded to the 4" fluted aluminum post. Please see Detail #8.
- c) **Base/Bell**: Decorative base shall be cast aluminum and welded to decorative post. Style shall match the attached decorative base option selected and final approval shall be coordinated with the City.

- d) **Scroll:** Decorative scrolls shall be one-piece cast aluminum and welded to each decorative street name flag (frames) and decorative post. Style shall match the attached decorative scroll options. Please see Details #10, #11, and #12.
- e) **Street Name Flags (also called Frames and/or Paddle):** The sign flag shall be made from a single piece of cast aluminum and be welded to the fluted aluminum post and scroll. The custom street name flags (frames) shall be dimensioned as shown in Detail #9. To be included in this item are new street name signs. Two per flag.
- f) **Prior to any fabrication, shop drawings shall be delivered to the City for each component in #1 and #2 above. The City shall review each shop drawing and provide its approval or disapproval.**

### 3) Welding

- a) Contractor shall provide warranty on all welds. Duration of warranty shall be noted in the bid tabulation.
- a) With the exception of the sign frame and backing being bolted onto a mounting bracket, all decorative components shall be fully welded to the post and not mechanically fastened. Welds shall be continuous, without spacing. **Street name sign flag frames must also be bolted to the pole.**
- b) All welds to use Alcotech Alloy 4043 filling wire (or equivalent), ISO designation: AlSi5 ANSA/AWS A.510 (ER&R) AMS 4190. All welds to be properly filed, grounded, cleaned and prepped.

### 4) Coating and Color

Contractor shall provide warranty period for color coating and gloss. Coating shall be either aluminum powder coating or automotive urethane grade paint priming and finishes.

The powder coating shall adhere to the following standards:

- a) The coating shall be applied in the following stages:
  - i. Stage 1 – All products coated shall receive an alkaline cleaner application followed by a fresh water rinse.
  - ii. Stage 2 – Phosphoric Acid 4% solution treatment with a fluoride accelerant followed by a reverse osmosis water rinse at ambient temperature. The rinse shall be followed by a high-pressure air spray to remove all moisture from the product.
  - iii. Stage 3 – Non-chrome Polymer sealer application.
  - iv. Stage 4 – Oven drying.
  - v. Stage 5 – Electro-static application of polyester powder in a downdraft spray booth and applied by articulated robot arm sprayer and over sprayed by an application technician. Polyester powder overspray shall be recoverable and reusable.
  - vi. Stage 6 – Oven curing to harden powder finish and create final appearance and adhesion to the substrate. Curing shall be in a cooling tunnel to prepare for un-racking.



The paint and primer shall adhere to the following standards:

- i. Stage 1 – Aluminum to be washed, removed of all oils and dirt
- ii. Stage 2 – Aluminum to be primed with two-part self-etching primer
- iii. Stage 3 – Finish coat shall be two part-part automotive urethane and have no imperfections

b) The finish-coat of the entire assembly shall be high gloss black.

## **5) Installation and Removal**

- a) All signs shall include installation in concrete foundations as specified in Detail #1. All signs will be located within the City limits and locations shall be approved by the City prior to installation.
- b) Concrete foundations shall be a minimum of sixteen inches (1.33-feet) in diameter for standard base and 36-inches (3 feet) deep regardless of base option, unless otherwise approved by the City. For any decorative base option the City selects, the concrete shall extend a minimum 3.5 inches outside the diameter of the selected base. Alternative size dimensions shall require the Contractor to provide engineering calculations showing the alternative base meets south Florida wind loading forces and break-a-way design standards.
- c) Contractor shall have the option of either bolting decorative post to a prefabricated concrete base or extending the sign post into the foundation forms and pouring the concrete base around the post. Both options require the bottom of the concrete base to be raised between 2.5 and 3.5 inches from existing ground surface. This is intended to protect the sign post from weed- wackers and lawn mowers.
- d) The contractor may be required to remove existing damaged or old signs and relocate them to the city stock yard or as directed by City staff. It may also be a requirement to remove old bases and backfill with suitable soils.

## **6) Acceptance**

- a) Contractor to provide a single unit for final approval prior to producing the remaining orders.

## **7) Purchasing Requirements**

- a) Prices established by this bid shall be honored for a minimum of 24-months from the date the Agreement is executed by the City. The Contractor shall honor any order made by the City for any amount of decorative sign assemblies as allowed for by these specifications and at the rates set forth in the Bid Tabulation for a period of 12-months after the City's execution date of the Agreement. At the conclusion of the term of Agreement, the City and Contractor shall each have the option to extend the term of Agreement for two additional 12-month periods.

b) It is the City's desire to eventually replace all damaged or old decorative signs within the City limits; however, complete replacement will depend on budget and time. This initial purchase focuses on a specific level of effort within the City for Fiscal Year 2017-18. The agreement will be in effect for two years with up to three additional annual renewals, at prices to be negotiated for subsequent years.

c) The City also desires to have a stock supply on hand to be used as needed for emergency repair/replacement. The exact quantity and sign types shall be determined upon notice to proceed.

**Detail #1: Sign Elevation with Decorative Components**

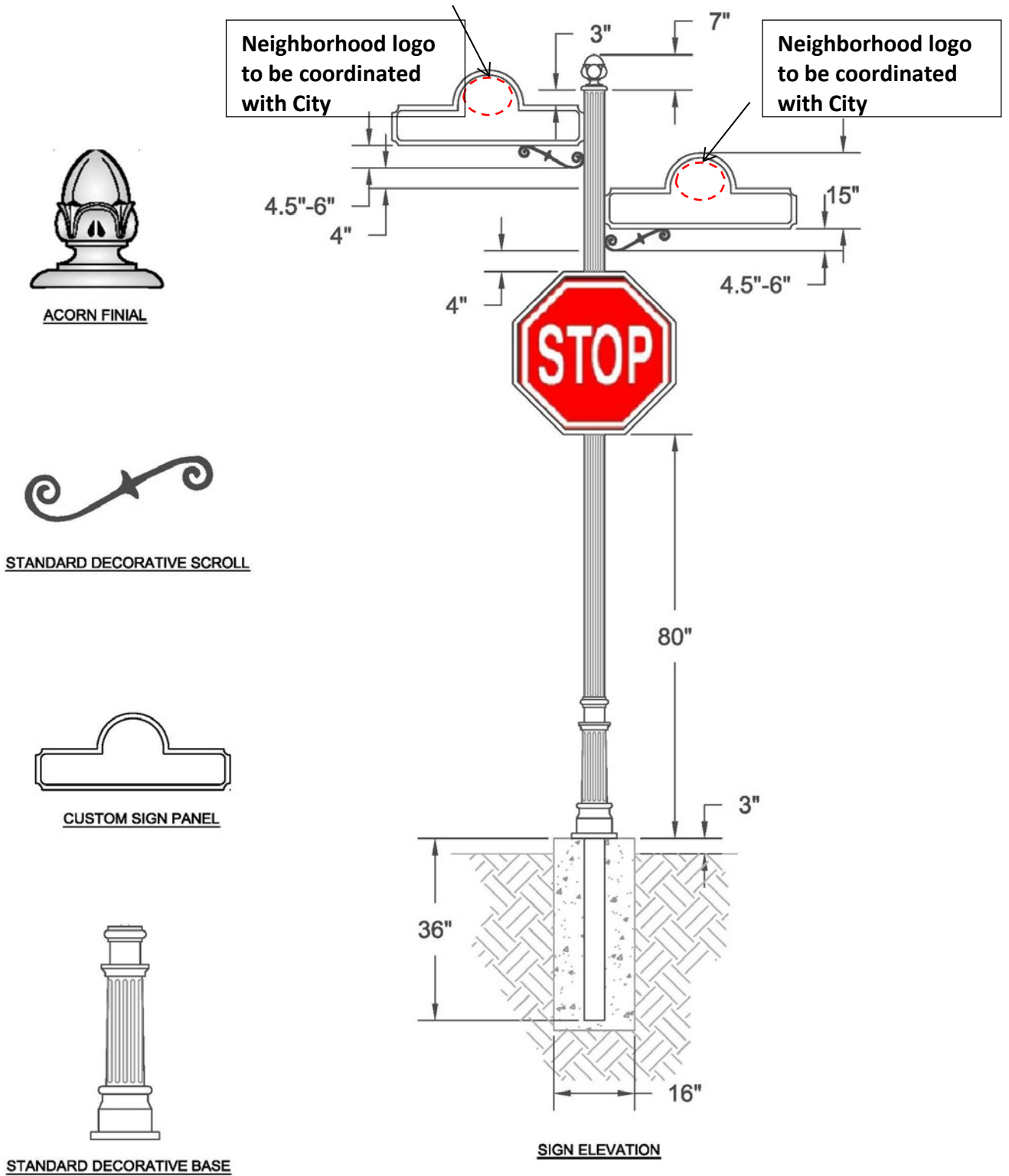

**\* Street name paddles/flags are shown at 180 degrees to illustrate spacing along pole, actual angle to be 90 degrees.**

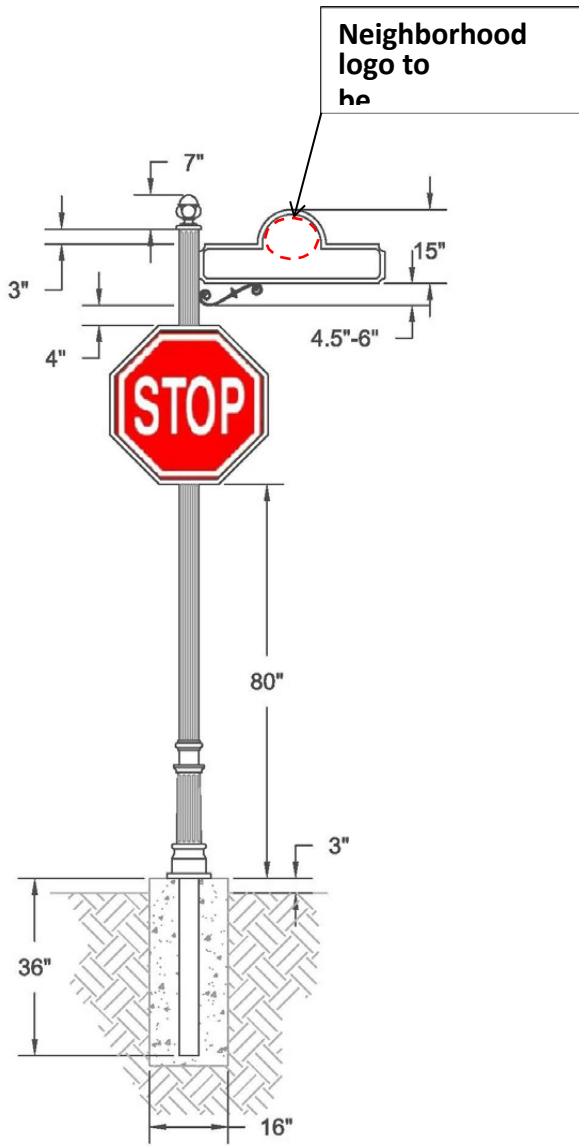

**Detail #2: Sign  
Elevation w/**

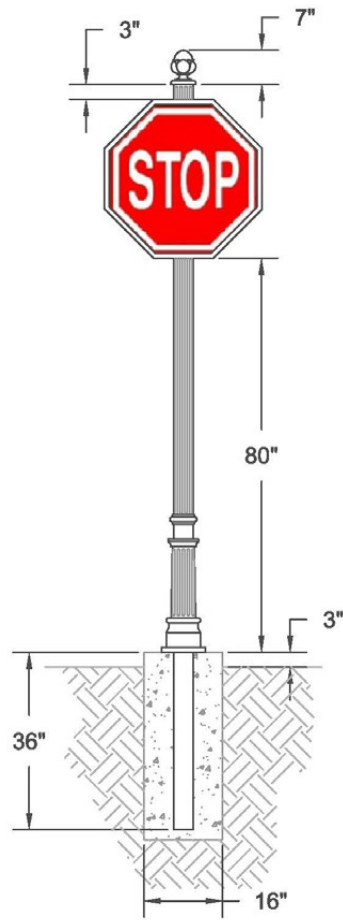

**Detail #3: Sign  
Elevation**

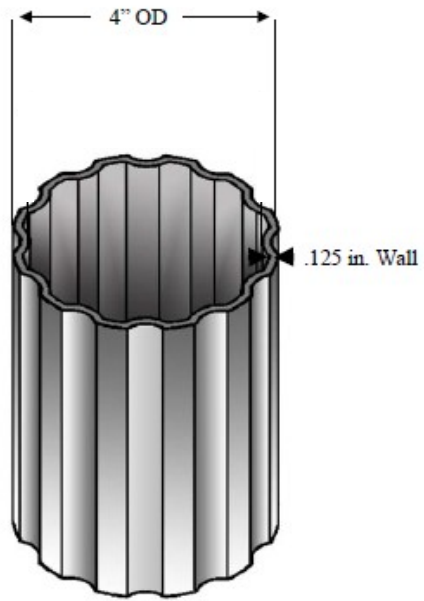

**Detail #6: 4" OD Fluted Pole Extruded**

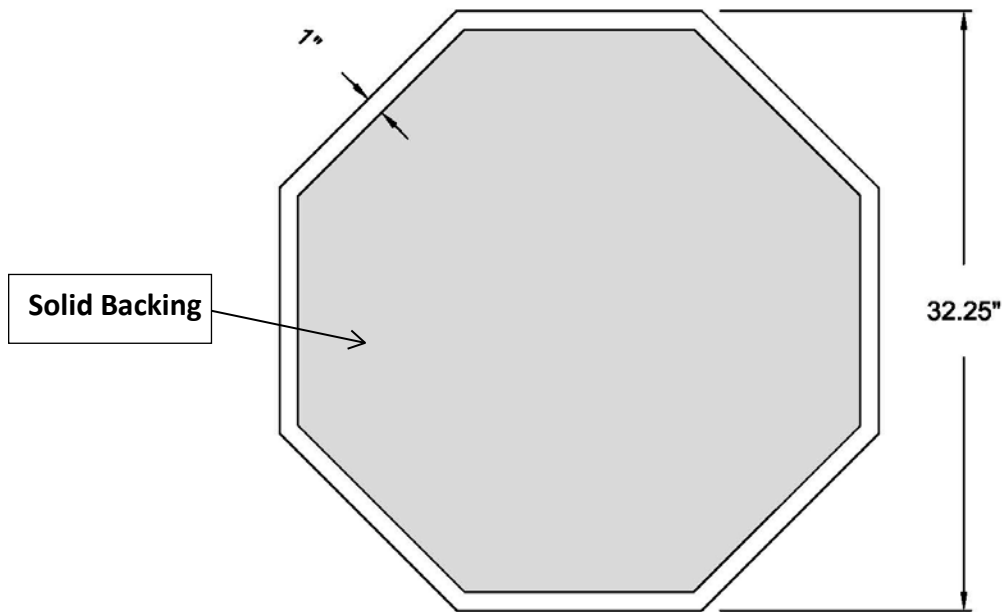

**Detail #7: Trim for 30" Stop Sign Cast Aluminum Alloy**

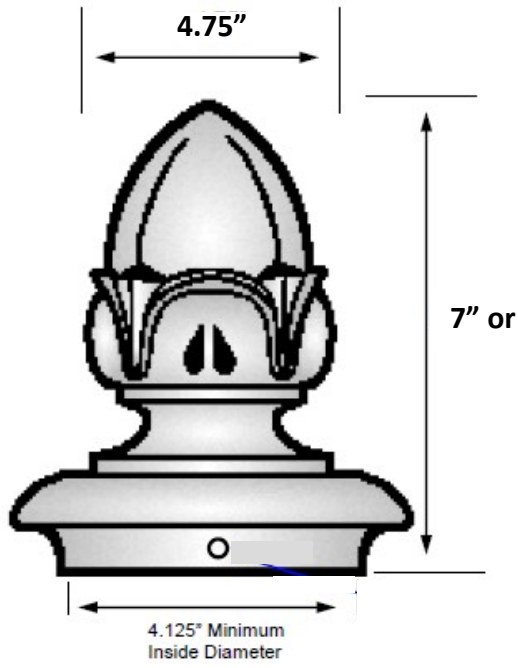

**Detail #8: Acorn Finial for 4" OD Pole Cast Aluminum Alloy**

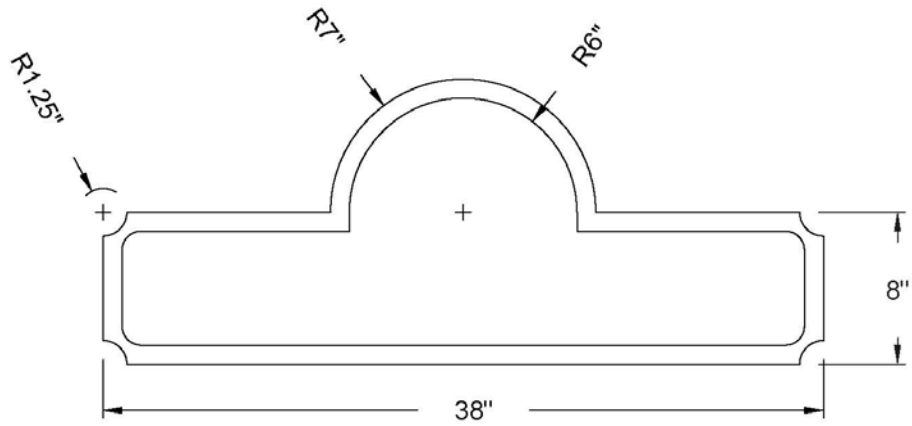

**Detail #9: Sign Paddle**  
**Dimensions**

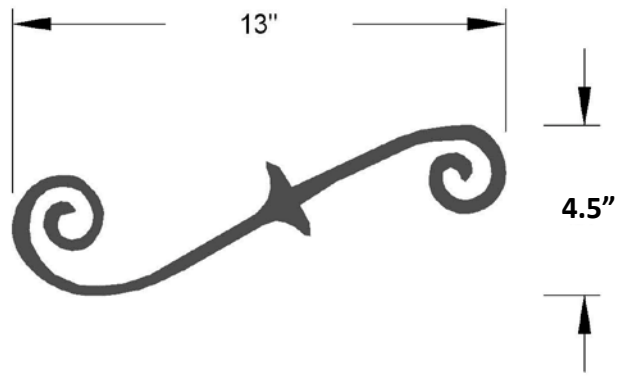

**Detail #10: Standard Decorative Scroll Dimensions**

# PRICE SCHEDULE

**This Sheet Must Be Completed and Returned With Bid**

City of Naples - Price Schedule for ITB #18-015 Decorative Street Signs

ITEM	DESCRIPTION OF MATERIALS AND SERVICE	UNITS	QUANTITY	UNIT PRICE	TOTAL
1	Supply & Install Fully Assembled Decorative STOP Sign with Two Street Name Flags (see detail #1)	EA	210	\$	\$
2	Supply & Install Fully Assembled Decorative STOP Sign with One Street Name Flag (see detail #2)	EA	80	\$	\$
3	Supply & Install Fully Assembled Decorative STOP Sign - No Street Name Flags (see detail #3)	EA	30	\$	\$
4	Supply Only Fully Assembled Decorative STOP Sign with Two Street Name Flags	EA	5	\$	\$
5 Part 1	Supply Only Fully Assembled Decorative STOP Sign with One Street Name Flag	EA	5	\$	\$
5 Part 2	Supply Only Fully Assembled Decorative STOP Sign - No Street Name Flags	EA	5	\$	\$
6	Supply & Install Fully Assembled Decorative Speed Limit Sign	EA	85	\$	\$
7	Supply Only Fully: Assembled Decorative Speed Limit Sign	EA	2	\$	\$
8	Supply & Install Fully Assembled YIELD Sign	EA	25	\$	\$
9	Supply Only Fully Assembled YIELD Sign	EA	2	\$	\$
10	Supply Split aluminum base for 4" round pole, size 36.25" Tall x 4" ID, color satin black, hardware included	EA	5	\$	\$
11	Supply 1" SQ aluminum tube frame and solid aluminum .080 backer for 30" x 30" stop signs, including 2 welded 4" back clamp	EA	3	\$	\$
12	Supply 1" SQ aluminum tube frame and solid aluminum .080 backer for 30" x 24" speed limit signs, including 2 welded 4" back clamp	EA	3	\$	\$
13	Supply 1" SQ aluminum tube frame and solid aluminum .080 backer for 30" x 30" yield sign, including 2 welded 4" back clamp	EA	3	\$	\$
14	Supply 1" SQ aluminum tube frame and solid aluminum .080 backer for 12" x 18" street sign, including 2 welded 4" back clamp	EA	3	\$	\$
15	Supply 4" round acorn finial, include set screw. Color satin black	EA	5	\$	\$
<b>TOTAL</b>					\$

WARRANTIES	DURATION (Years)
1 Welds, bolts, rivets, sign adhesive.	
2 Color and gloss	
3 Materials, foundations and workmanship	

**Company Name:** \_\_\_\_\_

**EIN:** \_\_\_\_\_

**Email:** \_\_\_\_\_

**Name and Title of individual completing this schedule:**

\_\_\_\_\_  
(Printed Name)
(Title)

**X** \_\_\_\_\_  
(Signature)
(Date)



## Attachment A - FEMA Contract Procurement Provisions

Current as of 1-9-17

### 2 C.F.R. §200.326 and 2 C.F.R. Part 200, Appendix II, Required Contract Clauses

Requirements under the Uniform Rules. A non-Federal entity's contracts must contain the applicable contract clauses described in Appendix II to the Uniform Rules (Contract Provisions for non-Federal Entity Contracts Under Federal Awards), which are set forth below. 2 C.F.R. § 200.326. For some of the required clauses we have included sample language or a reference a non-Federal entity can go to in order to find sample language. Please be aware that this is sample language only and that the non-Federal entity alone is responsible ensuring that all language included in their contracts meets the requirements of 2 C.F.R. § 200.326 and 2 C.F.R. Part 200, Appendix II. We do not include sample language for certain required clauses (remedies, termination for cause and convenience, changes) as these must necessarily be written based on the non-Federal entity's own procedures in that area.

#### 1. Remedies.

- a. Standard: Contracts for more than the simplified acquisition threshold (\$150,000) must address administrative, contractual, or legal remedies in instances where contractors violate or breach contract terms, and provide for such sanctions and penalties as appropriate. See 2 C.F.R. Part 200, Appendix II, ¶ A.
- b. Applicability: This requirement applies to all FEMA grant and cooperative agreement programs.

#### 2. Termination for Cause and Convenience.

- a. All contracts in excess of \$10,000 must address termination for cause and for convenience by the non-Federal entity including the manner by which it will be effected and the basis for settlement. See 2 C.F.R. Part 200, Appendix II, ¶ B.
- b. Applicability. This requirement applies to all FEMA grant and cooperative agreement programs.

#### 3. Equal Employment Opportunity.

- a. Standard. Except as otherwise provided under 41 C.F.R. Part 60, all contracts that meet the definition of "federally assisted construction contract" in 41 C.F.R. § 60-1.3 must include the equal opportunity clause provided under 41 C.F.R. § 60-1.4(b), in accordance with Executive Order 11246, *Equal Employment Opportunity* (30 Fed. Reg. 12319, 12935, 3 C.F.R. Part, 1964-1965 Comp., p. 339), as amended by Executive Order 11375, *Amending Executive Order 11246 Relating to Equal Employment Opportunity*, and implementing regulations at 41 C.F.R. Part 60 (Office of Federal Contract Compliance Programs, Equal Employment Opportunity, Department of Labor). See 2 C.F.R. Part 200, Appendix II, ¶ C.
- b. Key Definitions.

- (1) Federally Assisted Construction Contract. The regulation at 41 C.F.R. § 60-1.3 defines a “federally assisted construction contract” as any agreement or modification thereof between any applicant and a person for construction work which is paid for in whole or in part with funds obtained from the Government or borrowed on the credit of the Government pursuant to any Federal program involving a grant, contract, loan, insurance, or guarantee, or undertaken pursuant to any Federal program involving such grant, contract, loan, insurance, or guarantee, or any application or modification thereof approved by the Government for a grant, contract, loan, insurance, or guarantee under which the applicant itself participates in the construction work.
- (2) Construction Work. The regulation at 41 C.F.R. § 60-1.3 defines “construction work” as the construction, rehabilitation, alteration, conversion, extension, demolition or repair of buildings, highways, or other changes or improvements to real property, including facilities providing utility services. The term also includes the supervision, inspection, and other onsite functions incidental to the actual construction.

- c. Applicability. This requirement applies to all FEMA grant and cooperative agreement programs.
- d. The regulation at 41 C.F.R. Part 60-1.4(b) requires the insertion of the following contract clause:

“During the performance of this contract, the contractor agrees as follows:

- (1) The contractor will not discriminate against any employee or applicant for employment because of race, color, religion, sex, or national origin. The contractor will take affirmative action to ensure that applicants are employed, and that employees are treated during employment without regard to their race, color, religion, sex, or national origin. Such action shall include, but not be limited to the following: Employment, upgrading, demotion, or transfer; recruitment or recruitment advertising; layoff or termination; rates of pay or other forms of compensation; and selection for training, including apprenticeship. The contractor agrees to post in conspicuous places, available to employees and applicants for employment, notices to be provided setting forth the provisions of this nondiscrimination clause.
- (2) The contractor will, in all solicitations or advertisements for employees placed by or on behalf of the contractor, state that all qualified applicants will receive considerations for employment without regard to race, color, religion, sex, or national origin.
- (3) The contractor will send to each labor union or representative of workers with which he has a collective bargaining agreement or other contract or understanding, a notice to be provided advising the said labor union or workers' representatives of the contractor's commitments under this section,

and shall post copies of the notice in conspicuous places available to employees and applicants for employment.

- (4) The contractor will comply with all provisions of Executive Order 11246 of September 24, 1965, and of the rules, regulations, and relevant orders of the Secretary of Labor.
- (5) The contractor will furnish all information and reports required by Executive Order 11246 of September 24, 1965, and by rules, regulations, and orders of the Secretary of Labor, or pursuant thereto, and will permit access to his books, records, and accounts by the administering agency and the Secretary of Labor for purposes of investigation to ascertain compliance with such rules, regulations, and orders.
- (6) In the event of the contractor's noncompliance with the nondiscrimination clauses of this contract or with any of the said rules, regulations, or orders, this contract may be canceled, terminated, or suspended in whole or in part and the contractor may be declared ineligible for further Government contracts or federally assisted construction contracts in accordance with procedures authorized in Executive Order 11246 of September 24, 1965, and such other sanctions as may be imposed and remedies invoked as provided in Executive Order 11246 of September 24, 1965, or by rule, regulation, or order of the Secretary of Labor, or as otherwise provided by law.
- (7) The contractor will include the portion of the sentence immediately preceding paragraph (1) and the provisions of paragraphs (1) through (7) in every subcontract or purchase order unless exempted by rules, regulations, or orders of the Secretary of Labor issued pursuant to section 204 of Executive Order 11246 of September 24, 1965, so that such provisions will be binding upon each subcontractor or vendor. The contractor will take such action with respect to any subcontract or purchase order as the administering agency may direct as a means of enforcing such provisions, including sanctions for noncompliance: Provided, however, That in the event a contractor becomes involved in, or is threatened with, litigation with a subcontractor or vendor as a result of such direction by the administering agency the contractor may request the United States to enter into such litigation to protect the interests of the United States."

#### 4. Davis Bacon Act and Copeland Anti-Kickback Act.

- a. Applicability of Davis-Bacon Act. The Davis-Bacon Act only applies to the emergency Management Preparedness Grant Program, Homeland Security Grant Program, Nonprofit Security Grant Program, Tribal Homeland Security Grant Program, Port Security Grant Program, and Transit Security Grant Program. **It does not apply to other FEMA grant and cooperative agreement programs, including the Public Assistance Program.**
- b. All prime construction contracts in excess of \$2,000 awarded by non-Federal entities must include a provision for compliance with the Davis-Bacon Act (40

U.S.C. §§ 3141-3144 and 3146-3148) as supplemented by Department of Labor regulations at 29 C.F.R. Part 5 (Labor Standards Provisions Applicable to Contracts Covering Federally Financed and Assisted Construction)). See 2 C.F.R. Part 200, Appendix II, ¶ D.

- c. In accordance with the statute, contractors must be required to pay wages to laborers and mechanics at a rate not less than the prevailing wages specified in a wage determination made by the Secretary of Labor. In addition, contractors must be required to pay wages not less than once a week.
- d. The non-Federal entity must place a copy of the current prevailing wage determination issued by the Department of Labor in each solicitation. The decision to award a contract or subcontract must be conditioned upon the acceptance of the wage determination. The non-Federal entity must report all suspected or reported violations to the Federal awarding agency.
- e. In contracts subject to the Davis-Bacon Act, the contracts must also include a provision for compliance with the Copeland “Anti-Kickback” Act (40 U.S.C. § 3145), as supplemented by Department of Labor regulations at 29 C.F.R. Part 3 (Contractors and Subcontractors on Public Building or Public Work Financed in Whole or in Part by Loans or Grants from the United States). The Copeland Anti-Kickback Act provides that each contractor or subrecipient must be prohibited from inducing, by any means, any person employed in the construction, completion, or repair of public work, to give up any part of the compensation to which he or she is otherwise entitled. The non-Federal entity must report all suspected or reported violations to FEMA.
- f. The regulation at 29 C.F.R. § 5.5(a) does provide the required contract clause that applies to compliance with both the Davis-Bacon and Copeland Acts. However, as discussed in the previous subsection, the Davis-Bacon Act does not apply to Public Assistance recipients and subrecipients. **In situations where the Davis-Bacon Act does not apply, neither does the Copeland “Anti-Kickback Act.”** However, for purposes of grant programs where both clauses do apply, FEMA requires the following contract clause:

“Compliance with the Copeland “Anti-Kickback” Act.

- (1) Contractor. The contractor shall comply with 18 U.S.C. § 874, 40 U.S.C. § 3145, and the requirements of 29 C.F.R. pt. 3 as may be applicable, which are incorporated by reference into this contract.
- (2) Subcontracts. The contractor or subcontractor shall insert in any subcontracts the clause above and such other clauses as the FEMA may by appropriate instructions require, and also a clause requiring the subcontractors to include these clauses in any lower tier subcontracts. The prime contractor shall be responsible for the compliance by any subcontractor or lower tier subcontractor with all of these contract clauses.

(3) Breach. A breach of the contract clauses above may be grounds for termination of the contract, and for debarment as a contractor and subcontractor as provided in 29 C.F.R. § 5.12.”

5. Contract Work Hours and Safety Standards Act.

- a. Applicability: This requirement applies to all FEMA grant and cooperative agreement programs.
- b. Where applicable (see 40 U.S.C. § 3701), all contracts awarded by the non-Federal entity in excess of \$100,000 that involve the employment of mechanics or laborers must include a provision for compliance with 40 U.S.C. §§ 3702 and 3704, as supplemented by Department of Labor regulations at 29 C.F.R. Part 5. See 2 C.F.R. Part 200, Appendix II, ¶ E.
- c. Under 40 U.S.C. § 3702, each contractor must be required to compute the wages of every mechanic and laborer on the basis of a standard work week of 40 hours. Work in excess of the standard work week is permissible provided that the worker is compensated at a rate of not less than one and a half times the basic rate of pay for all hours worked in excess of 40 hours in the work week.
- d. The requirements of 40 U.S.C. § 3704 are applicable to construction work and provide that no laborer or mechanic must be required to work in surroundings or under working conditions which are unsanitary, hazardous or dangerous. These requirements do not apply to the purchases of supplies or materials or articles ordinarily available on the open market, or contracts for transportation or transmission of intelligence.
- e. The regulation at 29 C.F.R. § 5.5(b) provides the required contract clause concerning compliance with the Contract Work Hours and Safety Standards Act:

“Compliance with the Contract Work Hours and Safety Standards Act.

- (1) Overtime requirements. No contractor or subcontractor contracting for any part of the contract work which may require or involve the employment of laborers or mechanics shall require or permit any such laborer or mechanic in any workweek in which he or she is employed on such work to work in excess of forty hours in such workweek unless such laborer or mechanic receives compensation at a rate not less than one and one-half times the basic rate of pay for all hours worked in excess of forty hours in such workweek.
- (2) Violation; liability for unpaid wages; liquidated damages. In the event of any violation of the clause set forth in paragraph (1) of this section the contractor and any subcontractor responsible therefor shall be liable for the unpaid wages. In addition, such contractor and subcontractor shall be liable to the United States (in the case of work

done under contract for the District of Columbia or a territory, to such District or to such territory), for liquidated damages. Such liquidated damages shall be computed with respect to each individual laborer or mechanic, including watchmen and guards, employed in violation of the clause set forth in paragraph (1) of this section, in the sum of \$10 for each calendar day on which such individual was required or permitted to work in excess of the standard workweek of forty hours without payment of the overtime wages required by the clause set forth in paragraph (1) of this section.

(3) Withholding for unpaid wages and liquidated damages. The (write in the name of the Federal agency or the loan or grant recipient) shall upon its own action or upon written request of an authorized representative of the Department of Labor withhold or cause to be withheld, from any moneys payable on account of work performed by the contractor or subcontractor under any such contract or any other Federal contract with the same prime contractor, or any other federally-assisted contract subject to the Contract Work Hours and Safety Standards Act, which is held by the same prime contractor, such sums as may be determined to be necessary to satisfy any liabilities of such contractor or subcontractor for unpaid wages and liquidated damages as provided in the clause set forth in paragraph (2) of this section.

(4) Subcontracts. The contractor or subcontractor shall insert in any subcontracts the clauses set forth in paragraph (1) through (4) of this section and also a clause requiring the subcontractors to include these clauses in any lower tier subcontracts. The prime contractor shall be responsible for compliance by any subcontractor or lower tier subcontractor with the clauses set forth in paragraphs (1) through (4) of this section.”

6. Rights to Inventions Made Under a Contract or Agreement.

- a. Stafford Act Disaster Grants. This requirement **does not apply to the Public Assistance**, Hazard Mitigation Grant Program, Fire Management Assistance Grant Program, Crisis Counseling Assistance and Training Grant Program, Disaster Case Management Grant Program, and Federal Assistance to Individuals and Households – Other Needs Assistance Grant Program, as FEMA awards under these programs do not meet the definition of “funding agreement.”
- b. If the FEMA award meets the definition of “funding agreement” under 37 C.F.R. § 401.2(a) and the non-Federal entity wishes to enter into a contract with a small business firm or nonprofit organization regarding the substitution of parties, assignment or performance of experimental, developmental, or research work under that “funding agreement,” the non-Federal entity must comply with the requirements of 37 C.F.R. Part 401 (Rights to Inventions Made by Nonprofit Organizations and Small Business Firms Under Government Grants, Contracts and Cooperative Agreements), and any implementing regulations issued by

FEMA. See 2 C.F.R. Part 200, Appendix II, ¶ F.

- c. The regulation at 37 C.F.R. § 401.2(a) currently defines “funding agreement” as any contract, grant, or cooperative agreement entered into between any Federal agency, other than the Tennessee Valley Authority, and any contractor for the performance of experimental, developmental, or research work funded in whole or in part by the Federal government. This term also includes any assignment, substitution of parties, or subcontract of any type entered into for the performance of experimental, developmental, or research work under a funding agreement as defined in the first sentence of this paragraph.

7. Clean Air Act and the Federal Water Pollution Control Act. Contracts of amounts in excess of \$150,000 must contain a provision that requires the contractor to agree to comply with all applicable standards, orders, or regulations issued pursuant to the Clean Air Act (42 U.S.C. §§ 7401-7671q) and the Federal Water Pollution Control Act as amended (33 U.S.C. §§ 1251-1387). Violations must be reported to FEMA and the Regional Office of the Environmental Protection Agency. See 2 C.F.R. Part 200, Appendix II, ¶ G.

- a. The following provides a sample contract clause concerning compliance for contracts of amounts in excess of \$150,000:

“Clean Air Act

(1) The contractor agrees to comply with all applicable standards, orders or regulations issued pursuant to the Clean Air Act, as amended, 42 U.S.C. § 7401 et seq.

(2) The contractor agrees to report each violation to the (name of the state agency or local or Indian tribal government) and understands and agrees that the (name of the state agency or local or Indian tribal government) will, in turn, report each violation as required to assure notification to the (name of recipient), Federal Emergency Management Agency, and the appropriate Environmental Protection Agency Regional Office.

(3) The contractor agrees to include these requirements in each subcontract exceeding \$150,000 financed in whole or in part with Federal assistance provided by FEMA.

Federal Water Pollution Control Act

(1) The contractor agrees to comply with all applicable standards, orders or regulations issued pursuant to the Federal Water Pollution Control Act, as amended, 33 U.S.C. 1251 et seq.

(2) The contractor agrees to report each violation to the (name of the state agency or local or Indian tribal government) and understands and agrees that the (name of the state agency or local or Indian tribal

government) will, in turn, report each violation as required to assure notification to the (name of recipient), Federal Emergency Management Agency, and the appropriate Environmental Protection Agency Regional Office.

(3) The contractor agrees to include these requirements in each subcontract exceeding \$150,000 financed in whole or in part with Federal assistance provided by FEMA.”

8. Debarment and Suspension.

- a. Applicability: This requirement applies to all FEMA grant and cooperative agreement programs.
- b. Non-federal entities and contractors are subject to the debarment and suspension regulations implementing Executive Order 12549, *Debarment and Suspension* (1986) and Executive Order 12689, *Debarment and Suspension* (1989) at 2 C.F.R. Part 180 and the Department of Homeland Security’s regulations at 2 C.F.R. Part 3000 (Nonprocurement Debarment and Suspension).
- c. These regulations restrict awards, subawards, and contracts with certain parties that are debarred, suspended, or otherwise excluded from or ineligible for participation in Federal assistance programs and activities. See 2 C.F.R. Part 200, Appendix II, ¶ H; and *Procurement Guidance for Recipients and Subrecipients Under 2 C.F.R. Part 200 (Uniform Rules): Supplement to the Public Assistance Procurement Disaster Assistance Team (PDAT) Field Manual Chapter IV, ¶ 6.d, and Appendix C, ¶ 2 [hereinafter PDAT Supplement]*. A contract award must not be made to parties listed in the SAM Exclusions. SAM Exclusions is the list maintained by the General Services Administration that contains the names of parties debarred, suspended, or otherwise excluded by agencies, as well as parties declared ineligible under statutory or regulatory authority other than Executive Order 12549. SAM exclusions can be accessed at [www.sam.gov](http://www.sam.gov). See 2 C.F.R. § 180.530; *PDAT Supplement*, Chapter IV, ¶ 6.d and Appendix C, ¶ 2.
- d. In general, an “excluded” party cannot receive a Federal grant award or a contract within the meaning of a “covered transaction,” to include subawards and subcontracts. This includes parties that receive Federal funding indirectly, such as contractors to recipients and subrecipients. The key to the exclusion is whether there is a “covered transaction,” which is any nonprocurement transaction (unless excepted) at either a “primary” or “secondary” tier. Although “covered transactions” do not include contracts awarded by the Federal Government for purposes of the nonprocurement common rule and DHS’s implementing regulations, it does include some contracts awarded by recipients and subrecipient.
- e. Specifically, a covered transaction includes the following contracts for goods or services:



Current as of 1-9-17

- (1) The contract is awarded by a recipient or subrecipient in the amount of at least \$25,000.
- (2) The contract requires the approval of FEMA, regardless of amount.
- (3) The contract is for federally-required audit services.
- (4) A subcontract is also a covered transaction if it is awarded by the contractor of a recipient or subrecipient and requires either the approval of FEMA or is in excess of \$25,000.

- d. The following provides a debarment and suspension clause. It incorporates an optional method of verifying that contractors are not excluded or disqualified:

“Suspension and Debarment

- (1) This contract is a covered transaction for purposes of 2 C.F.R. pt. 180 and 2 C.F.R. pt. 3000. As such the contractor is required to verify that none of the contractor, its principals (defined at 2 C.F.R. § 180.995), or its affiliates (defined at 2 C.F.R. § 180.905) are excluded (defined at 2 C.F.R. § 180.940) or disqualified (defined at 2 C.F.R. § 180.935).
- (2) The contractor must comply with 2 C.F.R. pt. 180, subpart C and 2 C.F.R. pt. 3000, subpart C and must include a requirement to comply with these regulations in any lower tier covered transaction it enters into.
- (3) This certification is a material representation of fact relied upon by (insert name of subrecipient). If it is later determined that the contractor did not comply with 2 C.F.R. pt. 180, subpart C and 2 C.F.R. pt. 3000, subpart C, in addition to remedies available to (name of state agency serving as recipient and name of subrecipient), the Federal Government may pursue available remedies, including but not limited to suspension and/or debarment.
- (4) The bidder or proposer agrees to comply with the requirements of 2 C.F.R. pt. 180, subpart C and 2 C.F.R. pt. 3000, subpart C while this offer is valid and throughout the period of any contract that may arise from this offer. The bidder or proposer further agrees to include a provision requiring such compliance in its lower tier covered transactions.”

9. Byrd Anti-Lobbying Amendment.

- a. Applicability: This requirement applies to all FEMA grant and cooperative agreement programs.
- b. Contractors that apply or bid for an award of \$100,000 or more must file the required certification. See 2 C.F.R. Part 200, Appendix II, ¶ I; 44 C.F.R. Part 18; *PDAT Supplement*, Chapter IV, 6.c; Appendix C, ¶ 4.
- c. Each tier certifies to the tier above that it will not and has not used Federal appropriated funds to pay any person or organization for influencing or

attempting to influence an officer or employee of any agency, a member of Congress, officer or employee of Congress, or an employee of a member of Congress in connection with obtaining any Federal contract, grant or any other award covered by 31 U.S.C. § 1352. Each tier must also disclose any lobbying with non-Federal funds that takes place in connection with obtaining any Federal award. Such disclosures are forwarded from tier to tier up to the non-Federal award. See PDAT Supplement, Chapter IV, ¶ 6.c and Appendix C, ¶ 4.

d. The following provides a Byrd Anti-Lobbying contract clause:

“Byrd Anti-Lobbying Amendment, 31 U.S.C. § 1352 (as amended)

Contractors who apply or bid for an award of \$100,000 or more shall file the required certification. Each tier certifies to the tier above that it will not and has not used Federal appropriated funds to pay any person or organization for influencing or attempting to influence an officer or employee of any agency, a member of Congress, officer or employee of Congress, or an employee of a member of Congress in connection with obtaining any Federal contract, grant, or any other award covered by 31 U.S.C. § 1352. Each tier shall also disclose any lobbying with non-Federal funds that takes place in connection with obtaining any Federal award. Such disclosures are forwarded from tier to tier up to the recipient.”

APPENDIX A, 44 C.F.R. PART 18 – CERTIFICATION REGARDING LOBBYING

Certification for Contracts, Grants, Loans, and Cooperative Agreements

(To be submitted with each bid or offer exceeding \$100,000)

The undersigned [Contractor] certifies, to the best of his or her knowledge, that:

1. No Federal appropriated funds have been paid or will be paid, by or on behalf of the undersigned, to any person for influencing or attempting to influence an officer or employee of an agency, a Member of Congress, an officer or employee of Congress, or an employee of a Member of Congress in connection with the awarding of any Federal contract, the making of any Federal grant, the making of any Federal loan, the entering into of any cooperative agreement, and the extension, continuation, renewal, amendment, or modification of any Federal contract, grant, loan, or cooperative agreement.
2. If any funds other than Federal appropriated funds have been paid or will be paid to any person for influencing or attempting to influence an officer or employee of any agency, a Member of Congress, an officer or employee of Congress, or an employee of a Member of Congress in connection with this Federal contract, grant, loan, or

cooperative agreement, the undersigned shall complete and submit Standard Form-LLL, "Disclosure Form to Report Lobbying," in accordance with its instructions.

3. The undersigned shall require that the language of this certification be included in the award documents for all subawards at all tiers (including subcontracts, subgrants, and contracts under grants, loans, and cooperative agreements) and that all subrecipients shall certify and disclose accordingly.

This certification is a material representation of fact upon which reliance was placed when this transaction was made or entered into. Submission of this certification is a prerequisite for making or entering into this transaction imposed by 31, U.S.C. § 1352 (as amended by the Lobbying Disclosure Act of 1995). Any person who fails to file the required certification shall be subject to a civil penalty of not less than \$10,000 and not more than \$100,000 for each such failure.

The Contractor, \_\_\_\_\_, certifies or affirms the truthfulness and accuracy of each statement of its certification and disclosure, if any. In addition, the Contractor understands and agrees that the provisions of 31 U.S.C. § 3801 *et seq.*, apply to this certification and disclosure, if any.

\_\_\_\_\_

Signature of Contractor's Authorized Official

\_\_\_\_\_

Name and Title of Contractor's Authorized Official

\_\_\_\_\_

Date"

10. Procurement of Recovered Materials.

- a. Applicability: This requirement applies to all FEMA grant and cooperative agreement programs.
- b. A non-Federal entity that is a state agency or agency of a political subdivision of a state and its contractors must comply with Section 6002 of the Solid Waste Disposal Act, Pub. L. No. 89-272 (1965) (codified as amended by the Resource Conservation and Recovery Act at 42 U.S.C. § 6962). See 2 C.F.R. Part 200, Appendix II, ¶ J; 2 C.F.R. § 200.322; *PDAT Supplement*, Chapter V, ¶ 7.
- c. The requirements of Section 6002 include procuring only items designated in guidelines of the EPA at 40 C.F.R. Part 247 that contain the highest percentage of recovered materials practicable, consistent with maintaining a satisfactory level of

competition, where the purchase price of the item exceeds \$10,000 or the value of the quantity acquired by the preceding fiscal year exceeded \$10,000; procuring solid waste management services in a manner that maximizes energy and resource recovery; and establishing an affirmative procurement program for procurement of recovered materials identified in the EPA guidelines.

- d. The following provides the clause that a state agency or agency of a political subdivision of a state and its contractors can include in contracts meeting the above contract thresholds:

“(1) In the performance of this contract, the Contractor shall make maximum use of products containing recovered materials that are EPA-designated items unless the product cannot be acquired—

(i) Competitively within a timeframe providing for compliance with the contract performance schedule;

(ii) Meeting contract performance requirements; or

(iii) At a reasonable price.

(2) Information about this requirement, along with the list of EPA-designate items, is available at EPA’s Comprehensive Procurement Guidelines web site, <https://www.epa.gov/smm/comprehensive-procurement-guideline-cpg-program>.”

#### 11. Additional FEMA Requirements.

- a. The Uniform Rules authorize FEMA to require additional provisions for non-Federal entity contracts. FEMA, pursuant to this authority, requires or recommends the following:

b. Changes.

To be eligible for FEMA assistance under the non-Federal entity’s FEMA grant or cooperative agreement, the cost of the change, modification, change order, or constructive change must be allowable, allocable, within the scope of its grant or cooperative agreement, and reasonable for the completion of project scope. FEMA recommends, therefore, that a non-Federal entity include a changes clause in its contract that describes how, if at all, changes can be made by either party to alter the method, price, or schedule of the work without breaching the contract. The language of the clause may differ depending on the nature of the contract and the end-item procured.

c. Access to Records.

All non-Federal entities must place into their contracts a provision that all contractors and their successors, transferees, assignees, and subcontractors acknowledge and

agree to comply with applicable provisions governing Department and FEMA access to records, accounts, documents, information, facilities, and staff. See DHS Standard Terms and Conditions, v 3.0, ¶ XXVI (2013).

d. The following provides a contract clause regarding access to records:

“Access to Records. The following access to records requirements apply to this contract:

(1) The contractor agrees to provide (insert name of state agency or local or Indian tribal government), (insert name of recipient), the FEMA Administrator, the Comptroller General of the United States, or any of their authorized representatives access to any books, documents, papers, and records of the Contractor which are directly pertinent to this contract for the purposes of making audits, examinations, excerpts, and transcriptions.

(2) The Contractor agrees to permit any of the foregoing parties to reproduce by any means whatsoever or to copy excerpts and transcriptions as reasonably needed.

(3) The contractor agrees to provide the FEMA Administrator or his authorized representatives access to construction or other work sites pertaining to the work being completed under the contract.”

12. DHS Seal, Logo, and Flags.

- a. All non-Federal entities must place in their contracts a provision that a contractor shall not use the DHS seal(s), logos, crests, or reproductions of flags or likenesses of DHS agency officials without specific FEMA pre-approval. See DHS Standard Terms and Conditions, v 3.0, ¶ XXV (2013).
- b. The following provides a contract clause regarding DHS Seal, Logo, and Flags: “The contractor shall not use the DHS seal(s), logos, crests, or reproductions of flags or likenesses of DHS agency officials without specific FEMA pre-approval.”

13. Compliance with Federal Law, Regulations, and Executive Orders.

- a. All non-Federal entities must place into their contracts an acknowledgement that FEMA financial assistance will be used to fund the contract along with the requirement that the contractor will comply with all applicable federal law, regulations, executive orders, and FEMA policies, procedures, and directives.
- b. The following provides a contract clause regarding Compliance with Federal Law, Regulations, and Executive Orders: “This is an acknowledgement that FEMA financial assistance will be used to fund the contract only. The contractor

Current as of 1-9-17

will comply with all applicable federal law, regulations, executive orders, FEMA policies, procedures, and directives.”

14. No Obligation by Federal Government.

- a. The non-Federal entity must include a provision in its contract that states that the Federal Government is not a party to the contract and is not subject to any obligations or liabilities to the non-Federal entity, contractor, or any other party pertaining to any matter resulting from the contract.
- b. The following provides a contract clause regarding no obligation by the Federal Government: “The Federal Government is not a party to this contract and is not subject to any obligations or liabilities to the non-Federal entity, contractor, or any other party pertaining to any matter resulting from the contract.”

15. Program Fraud and False or Fraudulent Statements or Related Acts.

- a. The non-Federal entity must include a provision in its contract that the contractor acknowledges that 31 U.S.C. Chap. 38 (Administrative Remedies for False Claims and Statements) applies to its actions pertaining to the contract.
- b. The following provides a contract clause regarding Fraud and False or Fraudulent or Related Acts: “The contractor acknowledges that 31 U.S.C. Chap. 38 (Administrative Remedies for False Claims and Statements) applies to the contractor’s actions pertaining to this contract.”