

INVITATION TO BID
CITY OF NAPLES
PURCHASING DIVISION
CITY HALL, 735 8TH STREET SOUTH
NAPLES, FL 34102
PH: 239-213-7100 FX: 239-213-7105

Cover Sheet

NOTIFICATION DATE: 04/05/18	TITLE Tennis Courts Upgrade Seagate Park	SOLICITATION NUMBER: 18-055	OPENING DATE & TIME: 04/26/2018 2:00 PM
PRE-BID CONFERENCE DATE, TIME AND LOCATION: A non-mandatory Pre-Bid conference and Walk-through will be held April 11, 2018 at 10:00 A.M. local time at the Tennis Courts site located at 650 Seagate Drive, Naples 34103			

LEGAL NAME OF PARTNERSHIP, CORPORATION OR INDIVIDUAL:	
MAILING ADDRESS:	
CITY-STATE-ZIP:	
PH:	EMAIL:
FX:	WEB ADDRESS:
AUTHORIZED SIGNATURE	DATE
PRINTED NAME/TITLE	

I certify that this bid is made without prior understanding, agreement, or connection with any corporation, firm, or person submitting a bid for the same materials, supplies, or equipment and is in all respects fair and without collusion or fraud. I agree to abide by all conditions of this bid and certify that I am authorized to sign this bid for the bidder. In submitting a bid to the City of Naples the bidder offers and agrees that if the bid is accepted, the bidder will convey, sell, assign or transfer to the City of Naples all rights, title, and interest in and to all causes of action it may now or hereafter acquire under the Anti-trust laws of the United States and the State of FL for price fixing relating to the particular commodities or services purchased or acquired by the City of Naples. At the City's discretion, such assignment shall be made and become effective at the time the City tenders final payment to the bidder.

FEI/EIN Number _____

Please initial by all that apply
 I acknowledge receipt/ review of the following addendum

_____ Addendum #1
 _____ Addendum #2
 _____ Addendum #3
 _____ Addendum #4

PLEASE NOTE THE FOLLOWING

- > This page **must be completed and returned** with your bid.
- > Bids must be **submitted in a sealed envelope, marked with solicitation number & opening date.**
- > All submissions must be received and date stamped by Purchasing staff prior to the above "**OPENING DATE & TIME**".
- > Submission received after the above opening date and time will not be accepted.
- > Evaluation scores will be available on the City of Naples web site www.naplesgov.com . **If you do not have computer access and want a copy of the evaluation scores, please enclose a stamped, self-addressed envelope with your bid.**

GENERAL CONDITIONS

TO ENSURE ACCEPTANCE OF THE PROPOSAL, PLEASE FOLLOW THESE INSTRUCTIONS. ANY AND ALL SPECIAL CONDITIONS, ATTACHED HERETO, HAVE PRECEDENCE.

- 1. SEALED PROPOSAL:** All proposals must be submitted in a sealed envelope. The face of the envelope shall contain the proposal name and proposal number. Proposals not submitted on attached cover form shall be rejected. All proposals are subject to the conditions specified herein. Those which do not comply with these conditions are subject to rejection.
- 2. EXECUTION OF PROPOSAL:** Proposal must contain a manual signature of authorized representative in the proposal section. Proposal must be typed or printed in ink. Use of erasable ink is not permitted. All corrections made by proposer to his proposal must be initialed.
- 3. NO PROPOSAL:** If not submitting a proposal, respond by returning the Statement of No Proposal and explain the reason in the spaces provided. Failure to respond 3 times in succession without justification shall be cause for removal of the supplier's name from the proposal mailing list. NOTE: To qualify as a respondent, proposer must submit a "NO PROPOSAL," and it must be received no later than the stated proposal opening date and hour.
- 4. PROPOSAL OPENING:** Shall be public, on the date and at the time specified on the proposal form. It is the proposer's responsibility to assure that his proposal is delivered at the proper time and place of the proposal opening. Proposals which for any reason are not so delivered will not be considered. Offers by telegram; telephone; or fax are not acceptable. Proposal files may be examined during normal working hours.
- 5. WITHDRAWAL OF PROPOSALS:** Withdrawal of a proposal within sixty (60) days after the opening of proposals is subject to suspension or debarment in accordance with Policy 7-4 for up to three years.
- 6. PRICES, TERMS and PAYMENT:** Firm Prices shall be proposal and include all packing, handling, shipping charges and delivery to the destination shown herein. Proposer is encouraged to offer cash discount for prompt invoice payment. Terms of less than 20 days will not be considered.
 - A. TAXES:** The City of Naples does not pay Federal Excise and Sales taxes on direct purchases of tangible personal property. See exemption number on face of purchase order. This exemption does not apply to purchases of tangible personal property made by contractors who use the tangible personal property in the performance of contracts for the improvement of City-owned real property.
 - B. MISTAKES:** Proposers are expected to examine the specifications, delivery schedule, proposal prices, extensions, and all instructions pertaining to supplies and services. Failure to do so will be at proposer's risk. In case of mistake in extension, the unit price will govern.
 - C. CONDITION AND PACKAGING:** It is understood and agreed that any item offered or shipped as a result of this proposal shall be a new, current standard production model available at the time of this proposal. All containers shall be suitable for storage or shipment, and all prices shall include standard commercial packaging.
 - D. SAFETY STANDARDS:** Unless otherwise stipulated in the proposal, all manufactured items and fabricated assemblies shall comply with applicable requirements of Occupational Safety and Health Act and any standards there under.
 - E. UNDERWRITERS' LABORATORIES:** Unless otherwise stipulated in the proposal, all manufactured items and fabricated assemblies shall carry U.L. approval and re-examination listing where such has been established.
 - F. PAYMENT:** Payment will be made by the buyer after the items awarded to a vendor have been received, inspected, and found to comply with award specifications, free of damage or defect and properly invoiced. All invoices shall bear the purchase order number. Payment for partial shipments shall not be made unless specified in the proposal. Failure to follow these instructions may result in delay in processing

invoices for payment. In addition, the purchase order number must appear on bills of lading, packages, cases, delivery lists and correspondence.

7. DELIVERY: Unless actual date of delivery is specified (or if specified delivery cannot be met), show number of days required to make delivery after receipt of purchase order in space provided. Delivery time may become a basis for making an award (see Special Conditions). Delivery shall be within the normal working hours of the user, Monday through Friday, unless otherwise specified.

8. MANUFACTURERS' NAMES AND APPROVED EQUIVALENTS: Any manufacturers' names, trade names, brand names, information and/or catalog numbers listed in a specification are for information and not intended to limit competition. The proposer may offer any brand for which he is an authorized representative, which meets or exceeds the specification for any item(s). If proposals are based on equivalent products, indicate on the proposal form the manufacturer's name and number. Proposer shall submit with his proposal, cuts, sketches, and descriptive literature, and/or complete specifications. Reference to literature submitted with a previous proposal will not satisfy this provision. The proposer shall also explain in detail the reason(s) why the proposed equivalent will meet the specifications and not be considered an exception thereto. Proposals which do not comply with these requirements are subject to rejection. Proposals lacking any written indication of intent to quote an alternate brand will be received and considered in complete compliance with the specifications as listed on the proposal form.

9. INTERPRETATIONS: Any questions concerning conditions and specifications shall be directed in writing to this office for receipt no later than ten (10) days prior to the proposal opening. Inquiries must reference the date of proposal opening and proposal number. Failure to comply with this condition will result in proposer waiving his right to dispute the proposal.

10. CONFLICT OF INTEREST: All proposal awards are subject to Section 2-973 Conflict of Interest, City of Naples Code of Ordinances, which states: *"No public officer or employee shall have or hold any employment or contractual relationship with any business entity or any agency which is subject to the regulation of or is doing business with the city; nor shall an officer or employee have or hold any employment or contractual relationship that will create a continuing or frequently recurring conflict between his private interests and the performance of his public duties or that would impede the full and faithful discharge of his public duties. Any member of the city council or any city officer or employee who willfully violates this section shall be guilty of malfeasance in office or position and shall forfeit his office or position. Violation of this section with the knowledge, express or implied, of the person or corporation contracting with or making a sale to the city shall render the contract or sale voidable by the city manager or the city council."*

11. AWARDS: As the best interest of the City may require, the right is reserved to make award(s) by individual item, group of items, all or none, or a combination thereof; to reject any and all proposals or waive any minor irregularity or technicality in proposals received.

12. ADDITIONAL QUANTITIES: For a period not exceeding ninety (90) days from the date of acceptance of this offer by the buyer, the right is reserved to acquire additional quantities up to but not exceeding those shown on proposal at the prices proposal in this invitation. If additional quantities are not acceptable, the proposal sheets must be noted "PROPOSAL IS FOR SPECIFIED QUANTITY ONLY." (THIS PARAGRAPH DOES NOT APPLY FOR A TERM CONTRACT.)

13. SERVICE AND WARRANTY: Unless otherwise specified, the proposer shall define any warranty service and replacements that will be provided during and subsequent to this contract. Proposers must explain on an attached sheet to what extent warranty and service facilities are provided.

14. SAMPLES: Samples of items, when called for, must be furnished free of expense, on or before proposal opening time and date, and if not destroyed may, upon request, be returned at the proposer's expense. Each individual sample must be labeled with proposer's name, manufacturer's brand name and number, proposal number and item reference. Request for return of samples shall be accompanied by instructions which include shipping authorization and name of carrier and must be received with your

proposal. If instructions are not received within this time, the commodities shall be disposed of by the City of Naples.

15. PROPOSAL PROTEST: The city has formal proposal protest procedures that are available on request.

16. INSPECTION, ACCEPTANCE AND TITLE: Inspection and acceptance will be at destination unless otherwise provided. Title and risk of loss or damage to all items shall be the responsibility of the contract supplier until accepted by the ordering agency, unless loss or damage results from negligence by the ordering

17. DISPUTES: In case of any doubt or difference of opinion as to the items to be furnished hereunder, the decision of the buyer shall be final and binding on both parties.

18. GOVERNMENTAL RESTRICTIONS: In the event any governmental restrictions may be imposed which would necessitate alteration of the material, quality, workmanship or performance of the items offered on this proposal prior to their delivery, it shall be the responsibility of the successful proposer to notify the buyer at once, indicating in his letter the specific regulation which required an alteration. The City reserves the right to accept any such alteration, including any price adjustments occasioned thereby, or to cancel the contract at no expense to the City.

19. LEGAL REQUIREMENTS: Applicable provision of all Federal, State, county and local laws, and of all ordinances, rules, and regulations shall govern development submittal and evaluation of all proposals received in response hereto and shall govern any and all claims and disputes which may arise between person(s) submitting a proposal response hereto and the City of Naples by and through its officers, employees and authorized representatives, or any other person, natural or otherwise; and lack of knowledge by any proposer shall not constitute a cognizable defense against the legal effect thereof.

20. PATENTS AND ROYALTIES: The proposer, without exception, shall indemnify and save harmless the City of Naples and its employees from liability of any nature or kind, including cost and expenses for or on account of any copyrighted, patented, or unpatented invention, process, or article manufactured or used in the performance of the contract, including its use by the City of Naples. If the proposer uses any design, device, or materials covered by letters, patent or copyright, it is mutually agreed and understood without exception that the proposal prices shall include all royalties or cost arising from the use of such design, device, or materials in any way involved in the work.

21. ADVERTISING: In submitting a proposal, proposer agrees not to use the results there from as a part of any commercial advertising.

22. ASSIGNMENT: Any Purchase Order issued pursuant to this proposal invitation and the monies which may become due hereunder are not assignable except with the prior written approval of the buyer.

23. LIABILITY: The supplier shall hold and save the City of Naples, its officers, agents, and employees harmless from liability of any kind in the performance of this contract.

24. PUBLIC ENTITY CRIMES: A person or affiliate who has been placed on the convicted vendor list following a conviction for a public entity crime may not submit a proposal on a contract to provide any goods or services to a public entity, may not submit a proposal on a contract with a public entity for the construction or repair of a public building or public work, may not submit proposals on leases of real property to a public entity, may not be awarded or perform work as a contractor, supplier, subcontractor, or consultant under a contract with any public entity, and may not transact business with any public entity in excess of the threshold amount provided in Section 287.017, for CATEGORY TWO for a period of 36 months from the date of being placed on the convicted vendor list.

25. DISCRIMINATION: An entity or affiliate who has been placed on the discriminatory vendor list may not submit a proposal on a contract to provide goods or services to a public entity, may not submit a

proposal on a contract with a public entity for the construction or repair of a public building or public work, may not submit proposals on leases of real property to a public entity, may not award or perform work as a contractor, supplier, subcontractor, or consultant under contract with any public entity, and may not transact business with any public entity.

26. COUNTY TAXES: No proposal shall be accepted from and no contract will be awarded to any person, firm or corporation that is in arrears to the government of Collier County, Florida.

27. OFFER EXTENDED TO OTHER GOVERNMENTAL ENTITIES: The City of Naples encourages and agrees to the successful proposer extending the pricing, terms and conditions of this solicitation or resultant contract to other governmental entities at the discretion of the successful proposer.

IF THIS PROPOSAL IS FOR A TERM CONTRACT, THE FOLLOWING CONDITIONS SHALL ALSO APPLY

28. ELIGIBLE USERS: All departments of the City of Naples are eligible to use this term contract. Such purchases shall be exempt from the competitive proposal requirements otherwise applying to their purchases.

29. PRICE ADJUSTMENTS: Any price decrease effectuated during the contract period by reason of market change shall be passed on to City of Naples. Price increases are not acceptable.

30. CANCELLATION: All contract obligations shall prevail for at least one hundred eighty (180) days after effective date of contract. After that period, for the protection of both parties, this contract may be cancelled in whole or in part by either party by giving thirty (30) days prior written notice to the other party.

31. RENEWAL: The City of Naples reserves the option to renew the period of this contract, or any portion thereof for up to two (2) additional periods. Renewal of the contract period shall be by mutual agreement in writing.

32. ABNORMAL QUANTITIES: While it is not anticipated, should any unusual or abnormal requirements arise, the City reserves the right to solicit separate proposals thereon.

33. FISCAL NON-FUNDING CLAUSE: In the event sufficient funds are not budgeted for a new fiscal period, the City shall notify the contractor of such occurrence and the contract shall terminate on the last day of the current fiscal year without penalty or expense to the City.

IF THIS PROPOSAL IS FOR PERFORMING A SERVICE, THE FOLLOWING CONDITIONS SHALL ALSO APPLY

34. ALTERNATIVE PROPOSALS: Proposers offering service delivery methods other than those permitted by the scope of work may submit a separate envelope clearly marked "ALTERNATIVE PROPOSAL". Alternative proposals will be deemed non-responsive and will not be considered for award. All such responses will, however, be examined prior to award. Such examination may result in cancellation of all proposals received to permit rewriting the scope of work to include the alternative method, or the alternative method may be considered for future requirements of the City of Naples.

35. ANTITRUST: By entering into a contract, the contractor conveys, sells, assigns and transfers to the City of Naples all rights, titles and interest it may now have or hereafter acquire under the antitrust laws of the United States and the State of Florida that relate to the particular goods or services purchased or acquired by the City of Naples under said contract.

36. PROPOSER INVESTIGATIONS: Before submitting a proposal, each proposer shall make all investigations and examinations necessary to ascertain all site conditions and requirements affecting the full performance of the contract and to verify any representations made by the City of Naples upon which the proposer will rely. If the proposer receives an award as a result of its proposal submission, failure to have made such investigations and examinations will in no way relieve the proposer from its obligation to comply in every detail with all provisions and requirements of the contract documents, nor will a plea of ignorance of such conditions and requirements be accepted as a basis for any claim whatsoever by the contractor for additional compensation.

37. CERTIFICATES AND LICENSES: The Contractor, at time of proposal, shall possess the correct occupational licenses, all professional licenses or other authorizations necessary to carry out and perform the work required by the City of Naples and Collier County for this project pursuant to all applicable Federal, State and Local Laws, Statutes, Ordinances, and rules and regulations of any kind.

38. CHANGE IN SCOPE OF WORK: The City of Naples may order changes in the work consisting of additions, deletions or other revisions within the general scope of the contract. No claims may be made by the contractor that the scope of the project or of the contractor's services has been changed, requiring changes to the amount of compensation to the contractor or other adjustments to the contract unless such changes or adjustments have been made by written amendment to the contract signed by the City of Naples and the contractor. If the contractor believes that any particular work is not within the scope of the project, is a material change, or will otherwise require more compensation to the contractor, the contractor must immediately notify the City in writing of this belief. If the City believes that the particular work is within the scope of the contract as written, the contractor will be ordered to and shall continue with the work as changed and at the cost stated for the work within the scope.

39. CONTRACTOR PERSONNEL: The City of Naples shall, throughout the life of the contract, have the right of reasonable rejection and approval of staff or subcontractors assigned to the work by the contractor. If the City reasonably rejects staff or subcontractors, the contractor must provide replacement staff or subcontractors satisfactory to the City in a timely manner and at no additional cost to the City. The day-to-day supervision and control of the contractor's employees and sub-contractors is the responsibility solely of the contractor.

40. COST REIMBURSEMENT: The contractor agrees that all incidental costs, including allowances for profit and tools of the trade, must be included in the proposal rates. If an arrangement is made between the contractor and the City to reimburse the contractor for the cost of materials provided in the performance of the work, the contractor shall be reimbursed in the following manner: The City shall reimburse the contractor on completion and acceptance of each assigned job, only for those materials actually used in the performance of the work that is supported by invoices issued by the suppliers of the contractor describing the quantity and cost of the materials purchased. No surcharge shall be added to the supplier's invoices or included in the contractor's invoice submitted to the City that would increase the dollar amount indicated on the supplier's invoice for the materials purchased for the assigned job.

41. EXCEPTIONS: Proposers taking exception to any part or section of the solicitation shall indicate such exceptions on the proposal form. Failure to indicate any exception will be interpreted as the proposer's intent to comply fully with the requirements as written. Conditional or qualified proposals, unless specifically allowed, shall be subject to rejection in whole or in part.

42. FAILURE TO DELIVER: In the event of the contractor to fail to deliver services in accordance with the contract terms and conditions, the City, after due oral or written notice, may procure the services from other sources and hold the contractor responsible for any resulting purchase and administrative costs. This remedy shall be in addition to any other remedies that the City may have.

43. FAILURE TO ENFORCE: Failure by the City at any time to enforce the provisions of the contract shall not be construed as a waiver of any such provisions. Such failure to enforce shall not affect the validity of the contract or any part thereof or the right of the City to enforce any provision at any time in accordance with its terms.

44. FORCE MAJEURE: The contractor shall not be held responsible for failure to perform the duties and responsibilities imposed by the contract due to legal strikes, fires, riots, rebellions and acts of God beyond the control of the contractor, unless otherwise specified in the contract.

45. INDEPENDENT CONTRACTOR: The contractor shall be legally considered an independent contractor and neither the contractor nor its employees shall, under any circumstances, be considered servants or agents of the City of Naples and the City of Naples shall be at no time legally responsible for any negligence or any wrongdoing by the contractor, its servants or agents. The City of Naples shall not withhold from the contract payments to the contractor any federal income taxes, Social Security tax, or any other amounts for benefits to the contractor. Further, the City shall not provide to the contractor any insurance coverage or other benefits, including Workers' Compensation normally provided by the City for its employees.

46. ORAL STATEMENTS: No oral statement of any person shall modify or otherwise affect the terms, conditions or specifications stated in this contract. All modifications to the contract must be made in writing by the City of Naples.

47. QUALIFICATIONS OF PROPOSERS: The proposer may be required, before the award of any contract, to show to the complete satisfaction of the City of Naples that it has the necessary facilities, ability, and financial resources to provide the service specified therein in a satisfactory manner. The proposer may also be required to give a past history and references in order to satisfy the City in regard to the proposer's qualifications. The City may make reasonable investigations deemed necessary and proper to determine the ability of the proposer to perform the work, and the proposer shall furnish to the City all information for this purpose that may be requested. The City reserves the right to reject any proposal if the evidence submitted by, or investigation of, the proposer fails to satisfy the City that the proposer is properly qualified to carry out the obligations of the contract and to complete the work described therein. Evaluation of the proposer's qualifications shall include:

- > The ability, capacity, skill and financial resources to perform the work or service.
- > The ability to perform the work service promptly or within the time specified, without delay.
- > The character, integrity, reputation, judgment, experience, and efficiency of the proposer.
- > The quality of performance of previous contracts or services.

48. QUALITY CONTROL: The contractor shall institute and maintain throughout the contract period a properly documented quality control program designed to ensure that the services are provided at all times and in all respects in accordance with the contract. The program shall include providing daily supervision and conducting frequent inspections of the contractor's staff and ensuring that accurate records are maintained describing the disposition of all complaints. The records so created shall be open to inspection by the City.

49. RECOVERY OF MONEY: Whenever, under the contract, any sum of money shall be recoverable from or payable by the contractor to the City, the same amount may be deducted from any sum due to the contractor under the contract or under any other contract between the contractor and the City. The rights of the City are in addition and without prejudice to any other right the City may have to claim the amount of any loss or damage suffered by the City on account of the acts or omissions of the contractor.

50. REQUIREMENTS CONTRACT: During the period of the contract, the contractor shall provide all the services described in the contract. The contractor understands and agrees that this is a requirements contract and that the City shall have no obligation to the contractor if no services are required. Any quantities that are included in the scope of work reflect the current expectations of the City for the period of the contract. The amount is only an estimate and the contractor understands and agrees that the City is under no obligation to the contractor to buy any amount of services as a result of having provided this estimate or of having any typical or measurable requirement in the past. The contractor further understands and agrees that the City may require services in excess of the estimated annual contract amount and that the quantity actually used whether in excess of, or less than, the estimated annual contract amount and that the quantity actually used

shall not give rise to any claim for compensation other than the total of the unit prices in the contract for the quantity actually used.

51. TERMINATION FOR CONVENIENCE: The performance of work under the contract may be terminated by the City in whole or in part whenever the City determines that termination is in the City's best interest. Any such termination shall be effected by the delivery to the contractor of a written notice of termination of at least seven (7) days before the date of termination, specifying the extent to which performance of the work under the contract is terminated and the date upon which such termination becomes effective. After receipt of a notice of termination, except as otherwise directed, the contractor shall stop work on the date of the receipt of the notice or other date specified in the notice; place no further orders or subcontracts for materials, services or facilities except as necessary for completion of such portion of the work not terminated; terminate all vendors and subcontracts; and settle all outstanding liabilities and claims.

52. TERMINATION FOR DEFAULT: The City of Naples reserves the right to terminate the contract if the City determines that the contractor has failed to perform satisfactorily the work required, as determined by the City. In the event the City decides to terminate the contract for failure to perform satisfactorily, the City shall give to the contractor at least seven (7) days written notice before the termination takes effect. The seven-day period will begin upon the mailing of notice by the City. If the contractor fails to cure the default within the seven (7) days specified in the notice and the contract is terminated for failure to perform satisfactorily, the contractor shall be entitled to receive compensation for all reasonable, allocable and allowable contract services satisfactorily performed by the contractor up to the date of termination that were accepted by the City prior to the termination. In the event the City terminates the contract because of the default of the contractor, the contractor shall be liable for all excess costs that the City is required to expend to complete the work under contract.

53. STATE AND FEDERAL EMPLOYMENT LAWS: Contractors providing service to the City are required to comply with all state and federal employment laws. This includes, but is not limited to, laws resulting from the Immigration and Reform and Control Act of 1986, wherein all employers are required to verify the identity and employment eligibility of all employees. The Department of Homeland Security, U.S. Citizenship and Immigration Services require employees and employers to complete Form I-9 and the employer must examine evidence of identity and employment eligibility within three business days of the date employment begins. Non compliant contractors will be subject to contract sanctions, up to and including contract termination.

54. CERTIFICATION REGARDING DEBARMENT, SUSPENSION, INELIGIBILITY, AND VOLUNTARY EXCLUSION: The contractor agrees to comply with Executive Order 12549 "Debarment and Suspension" and 2 CFR 180 "OMB Guidelines to Agencies on Government wide Debarment and Suspension." These rules require all contractors using federal funds not be debarred or suspended from doing business with the Federal Government. This includes sub-recipients and lower tier participant for covered transactions. Signing and submitting this document certified the organization and its principals are not presently debarred, suspended, proposed for debarment, declared ineligible, or voluntarily excluded from participation in this transaction by any federal department or agency, and further have not within the preceding three-year period been convicted of or had a civil judgment rendered against them for commission of fraud or a criminal offense in connection with obtaining, attempting to obtain, or performing a public (Federal, State or local) transaction.

THE CITY OF NAPLES IS AN EQUAL OPPORTUNITY EMPLOYER

GENERAL INSURANCE REQUIREMENTS

The Contractor shall not commence work until he has obtained all the insurance required under this heading, and until such insurance has been approved by the Owner, nor shall the Contractor allow any subcontractor to commence work until all similar insurance required of the subcontractor has also been obtained and approved by the Owner.

Certificates of insurance must be issued by an authorized representative of the insurance company at the request and direction of the policyholder and must include sufficient information so as to identify the coverage and the contract for Owner's improvements for which they are issued. Certificates of insurance must be issued by a nationally recognized insurance company with a Best's Rating of no less than B+VII, satisfactory to the Owner, and duly licensed to do business in the state of said Contract.

The Contractor shall procure and maintain, during the life of this Contract, Workmen's Compensation Insurance for all of his employees to be engaged in work under this Contract, and he shall require any subcontractor similarly to provide Workmen's Compensation Insurance for all of the latter's employees to be engaged in such work, unless such employees are covered by the protection afforded by the Contractor's insurance. In case any employees are to be engaged in hazardous work under this Contract, and are not protected under this Workmen's Compensation statute, the Contractor shall provide, and shall cause each subcontractor to provide, adequate coverage for the protection of such employees. It is acceptable to use a State-approved Workmen's Compensation Self-Insurance fund.

The Contractor shall take out and maintain during the life of this Contract, Public Liability and Property Damage and shall include Contractual Liability, Personal Injury, Libel, Slander, False Arrest, Malicious Prosecution, Wrongful Entry or Eviction, Broad Form Property Damage, Products, Completed Operations and XCU Coverage to be included on an occurrence basis, and to the full extent of the Contract to protect him, the Owner, and any subcontractor performing work covered by this Contract from damages for personal injury, including accidental death, as well as from claims for property damage, which may arise from operations under this contract, whether such operations be by himself or by a subcontractor, or by anyone directly or indirectly employed by either of them. The Contractor shall also maintain automobile liability insurance including "non-owned and hired" coverage. The entire cost of this insurance shall be borne by the Contractor.

The amount of such insurance shall be no less than \$1,000,000 annual aggregate for bodily injury and property damage combined per occurrence.

The City of Naples must be named as Additional Insured on the insurance certificate and the following must also be stated on the certificate. "These coverage's are primary to all other coverage's the City possesses for this contract only." The City of Naples shall be named as the Certificate Holder. The Certificate Holder shall read as follows:

The City of Naples
735 Eighth Street South
Naples, Florida 34102

No City Division, Department, or individual name should appear on the Certificate.
No other format will be acceptable.

The Certificate must state the solicitation number and title.

When using the ACORD 25 – Certificate of Insurance only the most current version will be accepted.

The City of Naples requires a copy of a cancellation notice in the event the policy is cancelled. The City of Naples shall be expressly endorsed onto the policy as a cancellation notice recipient.

Proof of insurance from the successful proposer is required at the time of issuance and award of a contract.

STATEMENT OF NO BID

If you will not be bidding on this product/service, please help us by completing and returning only this page to:

City of Naples, Purchasing Division
City Hall, 735 8th Street South
Naples, FL 34102
Fax 239-213-7105

Bid # _____ and Description: _____

We, the undersigned, decline to bid on the above project for the following reason(s):

- ___ We are not able to respond to the Invitation to Bid by the specified deadline.
- ___ Our Company does not offer this product or service.
- ___ Our current work schedule will not permit us to perform the required services.
- ___ Specifications are incomplete, or information is unclear (Please explain below).

___ Other (Please specify below)

Company Name _____

PH _____ Email _____

Name and Title of individual completing this form:

(Printed Name) (Title)

(Signature) (Date)

REFERENCES

THIS SHEET MUST BE COMPLETED AND RETURNED WITH BID

PROVIDE AT LEAST THREE REFERENCES FOR WHOM YOUR COMPANY HAS PROVIDED SAME OR SIMILAR SERVICES WITHIN THE LAST 2 YEARS.

COMPANY NAME: _____

ADDRESS: _____

TELEPHONE: _____

CONTACT PERSON: _____

CONTACT E-MAIL ADDRESS: _____

COMPANY NAME: _____

ADDRESS: _____

TELEPHONE: _____

CONTACT PERSON: _____

CONTACT E-MAIL ADDRESS: _____

COMPANY NAME: _____

ADDRESS: _____

TELEPHONE: _____

CONTACT PERSON: _____

CONTACT E-MAIL ADDRESS: _____

Submitting Vendor Name: _____

CONSTRUCTION
SPECIAL CONDITIONS

A. TERMS OF CONTRACT

The resulting contract will commence on award and be in effect until completion of the project. Services to be rendered by the contractor shall be commenced subsequent to the execution of an agreement and upon written Notice to Proceed from the City. Project must be completed by the contract dates specified within the Notice to Proceed for construction. Should contractor fail to complete the project within this timeframe, daily LIQUIDATED DAMAGES in an amount of \$500.00 per day will be assessed.

B. PROHIBITION OF CONTACT

Under no circumstances should any prospective organization or individual, or anyone acting for or on behalf of a prospective organization or individual, seek to influence or gain the support of any member of the City Council, public official or City staff favorable to the interest of any prospective organization or individual. Likewise, contact with City Council, any public official or city staff against the interests of other prospective organization (s) and or individual(s) is prohibited. Any such activities will result in the exclusion of the prospective organization or individual from consideration by the City.

C. REFERENCES

Bidder must submit a minimum of three references on the form provided. Additionally, a signed and dated IRS W-9 form with EIN is required from all vendors.

D. STATEMENT OF NO BID

If you will not be bidding on this producer/service, please help us by completing and returning the Statement of No Bid.

E. BID FORMAT

The Contract, if awarded, will be awarded on the basis of material and equipment illustrated and described on the Drawings or specified in the Specification. If a substitution or an “or equal” item is proposed, the proposer must submit this information to the City of Naples Purchasing Department ten (10) days prior to the Proposal Date for evaluation as an acceptable substitution or an “or equal” item. If the substitution or the “or equal” item is accepted, the City of Naples will issue an Addendum to all Proposers listing the allowable substitution or the “or equal” item. The cost of changes in related work, additional drawings which may be required to illustrate or define the substitute or “or equal” equipment and its relationship to the other parts or portions of the Work shall be paid by the Contractor. No change will be made in the amount of time in which to complete the Work or in the liquidated damages.

F. BID SECURITY / BID BOND

It is the policy of the City of Naples to require a Bid Bond for all construction-related sealed bids estimated to be in excess of \$100,000. A bid bond or equivalent financial security in the amount of five (5) percent of the bid price shall be required and must accompany all bids. The Bid Bond is to be provided by a surety company authorized to do business in the State of Florida or otherwise supplied in a form satisfactory to the

City. The bid bond must be submitted with the bid. When the invitation for bids requires a bid bond, noncompliance will result in rejection of the bid. Note that failure or refusal of the awarded bidder to enter into a contract within twenty (20) calendar days after receipt of said contract will result in damages to the City and bid bond will be forfeited to the City as liquidated damages.

G. PROPOSAL CONSTRUCTION PERFORMANCE & PAYMENT BONDS

A Performance and Payment Bond will be required of the Awarded Proposer for any contract that is in excess of \$100,000.00 dollars and will be in an amount equal to 100 (%) percent of the price specified in the Contract. The bond(s) shall be executed by a surety company authorized to do business in the State of Florida, or otherwise secured in a manner satisfactory to the City for the protection of all persons supplying labor and material to the contractor or its subcontractors for the performance of the work provided for in the contract. Proof of insurance from the successful proposer is required at the time of issuance and award of a contract.

H. QUESTIONS

Questions regarding this proposer packet must be received in writing in the Purchasing Division **NO LATER THAN TEN CALENDAR DAYS PRIOR TO THE BID OPENING DATE TO ENSURE AN ANSWER IS PROVIDED PRIOR TO CLOSING.**

Direct all questions to:
Gerald “Jed” Secory, MBA / CPPO / CPM
Purchasing and Contracts Manager
City of Naples, Purchasing Division
735 8th Street South
Naples, Florida 34102
PH: (239) 213-7102 FX: (239) 213-7105
Jsecory@naplesgov.com

SUBMISSION CHECKLIST

Bidder should check off each of the following items as completed and submit with bid response:

CHECKLIST ELEMENTS	INCLUDED
<ul style="list-style-type: none"> Submit one (1) original signature and one (1) copy of your original bid / document AND a Windows© compatible PDF of the original document on a CD or Flash / Thumb Drive that is clearly labeled. 	
<ul style="list-style-type: none"> Include any required drawings; descriptive literature; qualifications; schedules; product compliance / exceptions; alternatives; questionnaire; references, forms, tabs, pricing/cost; and any information required of the proposer identified in the text of the bid including information for bid evaluation. 	
<ul style="list-style-type: none"> Include any Professional Licenses that qualify the firm for this solicitation as well as applicable bond documents, if required. Note if you are not a single prime contractor. List all subcontractors to be used for our project in your bid/proposal and their professional licenses. 	
<ul style="list-style-type: none"> Mandatory FORMS from this document to be included are: <u>Cover Sheet</u>, <u>References Sheet</u>, <u>Submission Checklist Sheet</u>, IRS <u>W-9</u> (NOV 2017) and <u>Cost Schedule</u>. 	
<ul style="list-style-type: none"> Have an authorized individual sign the appropriate pages including the <u>Cover Sheet</u> with bid addenda initialed. 	
<ul style="list-style-type: none"> Bid document must to be received by the OPENING DATE & TIME indicated on the Cover Sheet. The mailing envelope must be addressed to: <div style="text-align: center;"> City of Naples Purchasing Division 735 8th Street South Naples, Florida 34102 </div> 	
The mailing envelope must be sealed and marked with: Number: 18-055 Title: Tennis Courts Upgrade – Seagate Park Opening Date: April 26, 2018	

ALL COURIER DELIVERED BIDS MUST HAVE THE BID NUMBER AND TITLE ON THE OUTSIDE OF THE COURIER PACKET.

Submitting Vendor Name: _____

At the discretion of the Purchasing Manager, bids or proposals with minor irregularities may be accepted and allowed to be corrected when in the best interest of the City.

Request for Taxpayer Identification Number and Certification

**Give Form to the
 requester. Do not
 send to the IRS.**

▶ Go to www.irs.gov/FormW9 for instructions and the latest information.

Print or type.
See Specific Instructions on page 3.

1 Name (as shown on your income tax return). Name is required on this line; do not leave this line blank.
2 Business name/disregarded entity name, if different from above
3 Check appropriate box for federal tax classification of the person whose name is entered on line 1. Check only one of the following seven boxes. <input type="checkbox"/> Individual/sole proprietor or single-member LLC <input type="checkbox"/> C Corporation <input type="checkbox"/> S Corporation <input type="checkbox"/> Partnership <input type="checkbox"/> Trust/estate <input type="checkbox"/> Limited liability company. Enter the tax classification (C=C corporation, S=S corporation, P=Partnership) ▶ _____ Note: Check the appropriate box in the line above for the tax classification of the single-member owner. Do not check LLC if the LLC is classified as a single-member LLC that is disregarded from the owner unless the owner of the LLC is another LLC that is not disregarded from the owner for U.S. federal tax purposes. Otherwise, a single-member LLC that is disregarded from the owner should check the appropriate box for the tax classification of its owner. <input type="checkbox"/> Other (see instructions) ▶ _____
4 Exemptions (codes apply only to certain entities, not individuals; see instructions on page 3): Exempt payee code (if any) _____ Exemption from FATCA reporting code (if any) _____ <i>(Applies to accounts maintained outside the U.S.)</i>
5 Address (number, street, and apt. or suite no.) See instructions.
6 City, state, and ZIP code
7 List account number(s) here (optional)
Requester's name and address (optional)

Part I Taxpayer Identification Number (TIN)

Enter your TIN in the appropriate box. The TIN provided must match the name given on line 1 to avoid backup withholding. For individuals, this is generally your social security number (SSN). However, for a resident alien, sole proprietor, or disregarded entity, see the instructions for Part I, later. For other entities, it is your employer identification number (EIN). If you do not have a number, see *How to get a TIN*, later.

Note: If the account is in more than one name, see the instructions for line 1. Also see *What Name and Number To Give the Requester* for guidelines on whose number to enter.

Social security number					
<table style="width: 100%; border-collapse: collapse;"> <tr> <td style="width: 25%; border: 1px solid black; height: 20px;"></td> <td style="width: 5%; border: 1px solid black; text-align: center;">-</td> <td style="width: 25%; border: 1px solid black; height: 20px;"></td> <td style="width: 5%; border: 1px solid black; text-align: center;">-</td> <td style="width: 40%; border: 1px solid black; height: 20px;"></td> </tr> </table>		-		-	
	-		-		
or					
Employer identification number					
<table style="width: 100%; border-collapse: collapse;"> <tr> <td style="width: 10%; border: 1px solid black; height: 20px;"></td> <td style="width: 5%; border: 1px solid black; text-align: center;">-</td> <td style="width: 90%; border: 1px solid black; height: 20px;"></td> </tr> </table>		-			
	-				

Part II Certification

Under penalties of perjury, I certify that:

1. The number shown on this form is my correct taxpayer identification number (or I am waiting for a number to be issued to me); and
2. I am not subject to backup withholding because: (a) I am exempt from backup withholding, or (b) I have not been notified by the Internal Revenue Service (IRS) that I am subject to backup withholding as a result of a failure to report all interest or dividends, or (c) the IRS has notified me that I am no longer subject to backup withholding; and
3. I am a U.S. citizen or other U.S. person (defined below); and
4. The FATCA code(s) entered on this form (if any) indicating that I am exempt from FATCA reporting is correct.

Certification instructions. You must cross out item 2 above if you have been notified by the IRS that you are currently subject to backup withholding because you have failed to report all interest and dividends on your tax return. For real estate transactions, item 2 does not apply. For mortgage interest paid, acquisition or abandonment of secured property, cancellation of debt, contributions to an individual retirement arrangement (IRA), and generally, payments other than interest and dividends, you are not required to sign the certification, but you must provide your correct TIN. See the instructions for Part II, later.

Sign Here

Signature of U.S. person ▶

Date ▶

General Instructions

Section references are to the Internal Revenue Code unless otherwise noted.

Future developments. For the latest information about developments related to Form W-9 and its instructions, such as legislation enacted after they were published, go to www.irs.gov/FormW9.

Purpose of Form

An individual or entity (Form W-9 requester) who is required to file an information return with the IRS must obtain your correct taxpayer identification number (TIN) which may be your social security number (SSN), individual taxpayer identification number (ITIN), adoption taxpayer identification number (ATIN), or employer identification number (EIN), to report on an information return the amount paid to you, or other amount reportable on an information return. Examples of information returns include, but are not limited to, the following.

- Form 1099-INT (interest earned or paid)

- Form 1099-DIV (dividends, including those from stocks or mutual funds)
 - Form 1099-MISC (various types of income, prizes, awards, or gross proceeds)
 - Form 1099-B (stock or mutual fund sales and certain other transactions by brokers)
 - Form 1099-S (proceeds from real estate transactions)
 - Form 1099-K (merchant card and third party network transactions)
 - Form 1098 (home mortgage interest), 1098-E (student loan interest), 1098-T (tuition)
 - Form 1099-C (canceled debt)
 - Form 1099-A (acquisition or abandonment of secured property)
- Use Form W-9 only if you are a U.S. person (including a resident alien), to provide your correct TIN.

If you do not return Form W-9 to the requester with a TIN, you might be subject to backup withholding. See What is backup withholding, later.

City of Naples FL
Invitation to Bid – 18-055
Tennis Courts Upgrade – Seagate Park

INDEX

		PAGE
COVER SHEET	REQUIRED	1
GENERAL CONDITIONS		2
GENERAL INSURANCE REQUIREMENTS		9
STATEMENT OF NO BID		10
REFERENCES	REQUIRED	11
SPECIAL CONDITIONS		12
SUBMISSION CHECKLIST	REQUIRED	14
IRS W-9 FORM	REQUIRED	15
PROJECT DESCRIPTION		17
COST SCHEDULE	REQUIRED	18
ATTACHMENT A - PROJECT PLAN DOCUMENTS WITH SPECIFICATIONS		19

PROJECT DESCRIPTION
Seagate Park Tennis Courts Upgrade
ITB # 18-055

Seagate Park Tennis Courts are located on West Street, Naples, adjacent to the Sea Gate Elementary School ball fields. The City is requesting proposals for the upgrade of the two courts. The base bid is the complete removal (approximately 13,000 SF) of the existing tennis courts and a total reconstruction including new asphalt (1.5"), new fencing, and new nets/ windscreens. The Alternate bid is for the resurfacing of the tennis courts including milling the entire court, patching all visible cracks, install a new asphalt lift (1"), new fencing, and new nets and/Windscreens.

Cost Schedue - Sea Gate Tennis Courts ITB #18-055

Base Bid - Rebuild Courts (Two)

	1	Demolition	LS	\$
	2	Repave courts	LS	\$
	3	New fencing	LS	\$
	4	Court surfacing	LS	\$
	5	Windscreens & Nets	LS	\$
	6	Permits	LS	\$
	7	General conditions/ Other items	LS	\$

Base Bid Total

\$

Alternate Bid - Repair Courts (Two)

	1	Limited demolition- mill Courts	LS	\$
	2	Limited rebuild courts- patching	LS	\$
	3	New fencing	LS	\$
	4	Court Surfacing	LS	\$
	5	New fencing	LS	\$
	6	Windscreens & Nets	LS	\$
	7	Permits	LS	\$
	8	General Conditions other Items	LS	\$

Alternate Bid Total

\$

Note: The City will award the project on what is in the best interets of the City based on available funding and the Base bid cost value or Alternate Bid cost value.

Company Name: _____

EIN: _____

Email: _____

Name and Title of individual completing this schedule:

(Printed Name)

(Title)

X _____

(Signature)

(Date)

ATTACHMENT A - PROJECT PLAN DOCUMENTS WITH SPECIFICATIONS

SPECIFICATIONS

Project Description:
BASE BID: The base bid To provide labor, materials, equipment, supervision, and insurance to complete the scope as clarified: The work includes the complete removal of the existing tennis courts and a total rebuild. This includes the tennis nets and net supports. The entire asphalt surface 1.5" thickness, The fence and fence posts and bases. Upon completion of the work the contractor shall finish grade and seed. All unused materials shall be removed from the site. The contractor shall Perform a flood test and fix any bird bath areas greater than 1/8" in depth. Apply 1 coat of acrylic re surface and two coats of Laykold color coatings by Laykold. rea (Colors shall be Pro Blue inside the playing area and Medium Green outside the playing area per USTA standards). Include all games lines, accurately laid out, masked, and sealed for sharpness. Paint with two coats white textured line paint.

ALTERNATE BID: The alternate bid is to resurface both courts without removing old asphalt. To provide labor, materials, equipment, supervision, and insurance to complete the scope as clarified:
 Clean and prep court for proper work to be done. Mill the entire court, patch all visible cracks and install a new asphalt lift 1" minimum. Perform a flood test and fix any bird bath areas within 1/8". Apply 1 coat of acrylic re surface and two coats of Laykold color coatings by Laykold. (color is to The Colors shall be Pro Blue inside the playing area and Medium Green outside the playing area per USTA standards). Include all games lines, accurately laid out, masked, and sealed for sharpness. Paint with two coats white textured line paint. Also include two new tennis court nets with straps. The removal of the existing fence and the installation of the new fencing is included in this bid. Provide new nets and straps. Provide all finished grading.

SPECIFICATIONS:

1.01 Asphalt And Preparation
 Remove all the asphalt and properly dispose of it off site. Prepare the site to lay new asphalt. Grading shall be done to a tolerance of plus or minus one (1) inch of the final sub-grade elevation. Rate and direction of slope shall be one (1) inch in ten (10) feet all in one plane from North to South. A compaction of 95% (Modified Proctor) is required and the soil shall be free of all roots and vegetation.

1.02 Construct one (2) all-weather tennis courts as shown with cut corners measuring 60 feet by 120 feet with cut corners.
 a. Base: The base shall consist of six (6) inches of base material topped with one and one-half (1 1/2) inches of compacted asphalt hot mix.
 After the asphalt has properly cured (approximately 30 days), apply (1) filler coat of Acrylic Resurfacer material to the entire court surface. Then (3) full coats of Color on the entire court surface. The Colors shall be Pro Blue inside the playing area and Medium Green outside the playing area (per USTA standards). No "birdbath" deeper than 1/8 of an inch shall exist after flooding the court and allowing one hour of time to elapse at a temperature of at least at 70 degrees Fahrenheit (21 degrees Celsius) in sunlight.

1.03 Remove the old fence and properly dispose of it off site. Then install a new fence installing footers approximately 9 inches on the outside of the new court substrate (108x120) The fence specifications shall be as Follows:
 Fencing: 9 ga. core black vinyl coated
 Line Posts: 2" schedule 40 Galvanized (painted black)
 Top, Bottom and Middle Rail: 1-5/8" Schedule 40 Galvanized (painted black)

Corner Posts: 2 1/2" schedule 40 galvanized (painted black)
 Gate Posts: 3" schedule 40 galvanized (painted black)

1.04 Install windscreens on the outside of each end of the court.
 The windscreens shall be 6' high and installed with the bottom of the screen at 2" above the court surface. The screen shall be precut to fit between the posts and shall be grommeted at 24" o.c.
 The screens shall meet the following specifications:
 Material: Fade resistant Polyester
 Density: 75%-85_
 Mesh: open
 Color: black
 Warranty: 5 year

1.05 Remove the old nets and provide new nets. The nets shall be professional quality equal to Tournament Deluxe Model TTN-3
 Constructed of durable 3mm braided black polyethylene netting
 Quadruple stitched heavy-duty polyester web headband with a 3/16" dia vinyl coated steel cable. Top five rows are double mesh
 Include synthetic taped bottom edges and grommeted side pockets with dowels. The net is to be 42' L x 42" W. Include a new adjustable center strap.

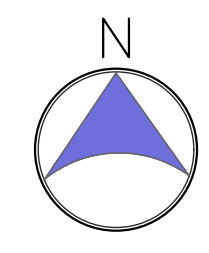
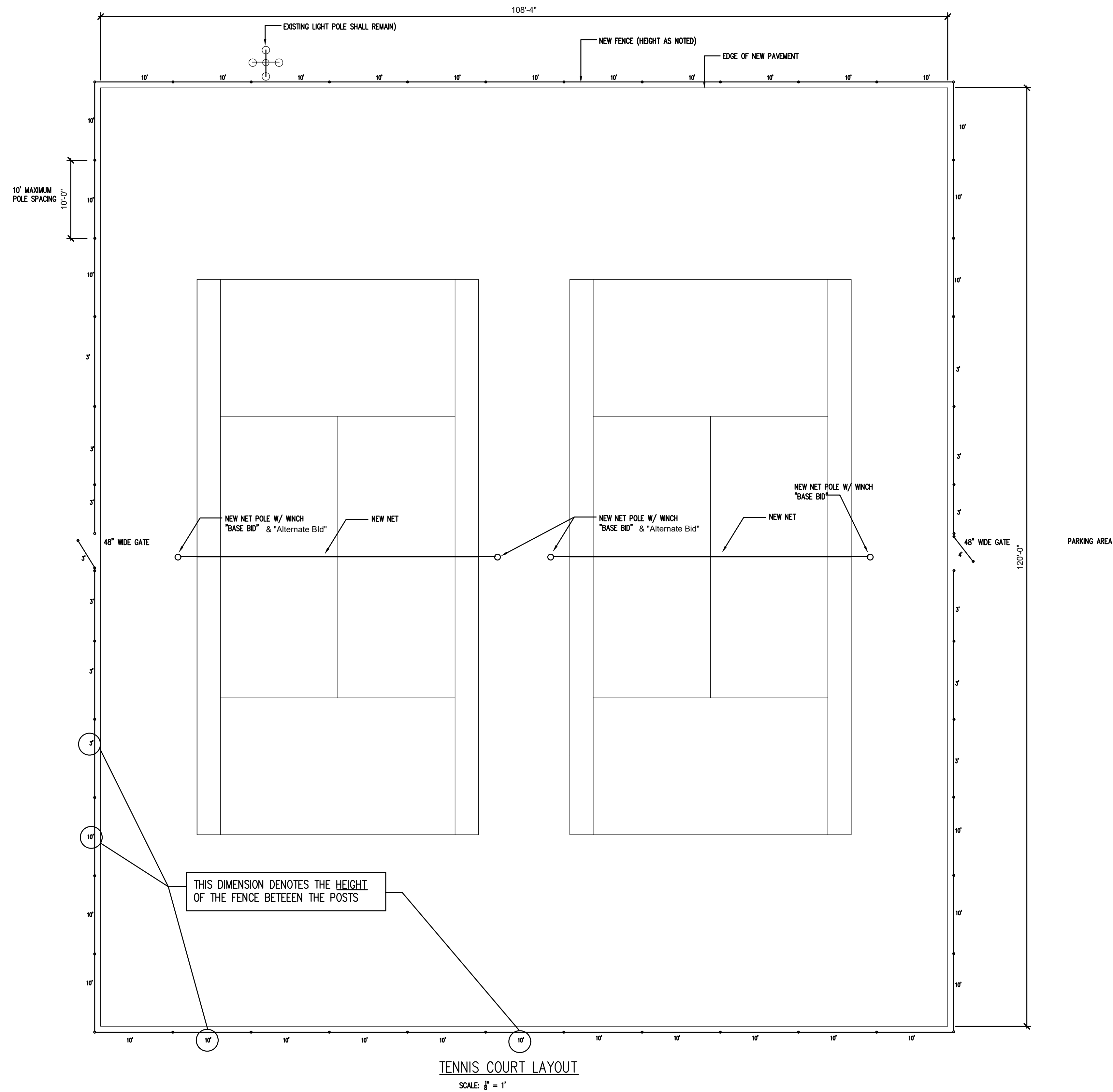
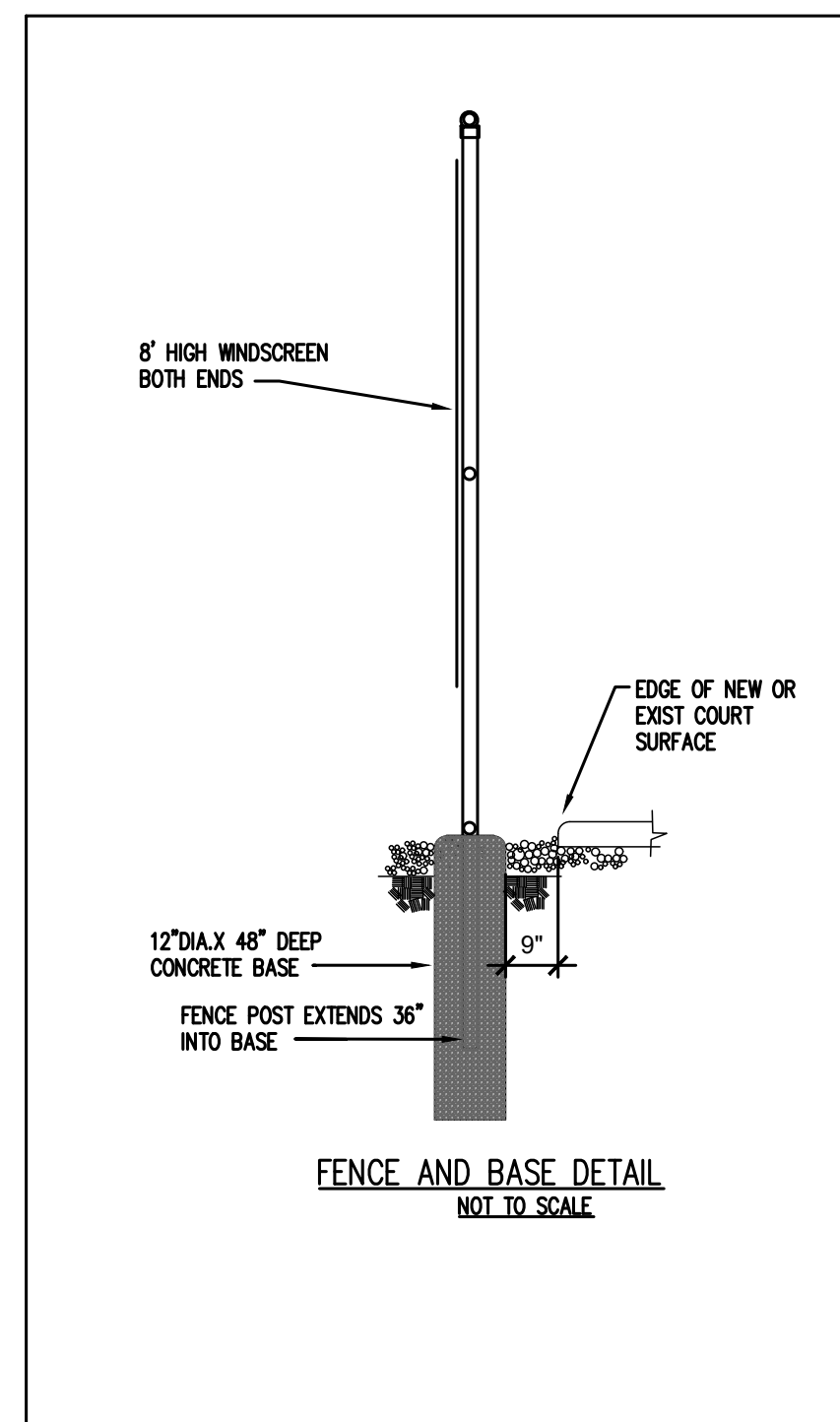

NO.	DATE	COMMENT

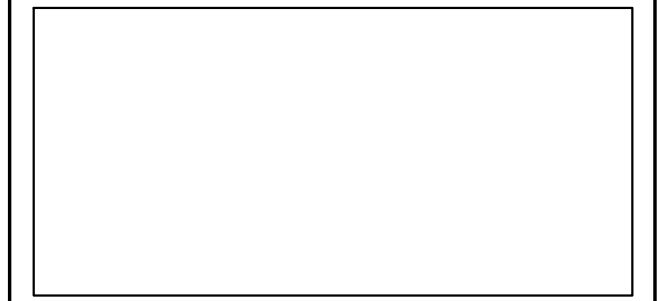

DRAWINGS PREPARED BY:
FIELDSTONE PROJECT MANAGEMENT
 1712 NORTH BAHAMA AVENUE
 MARCO ISLAND, FLORIDA 34145
 PHONE: (863) 646-6555 FAX: (863) 646-6572

PROJECT
TENNIS COURT REPAIR
 SEA GATE PARK
 WEST STREET
 NAPLES, FLORIDA

SHEET TITLE
PLANS AND SPECIFICATIONS



DRAWN BY DC	DWG NUMBER L-1
CHECKED BY RJ	
DATE FEBRUARY 27, 2018	